

A ↑

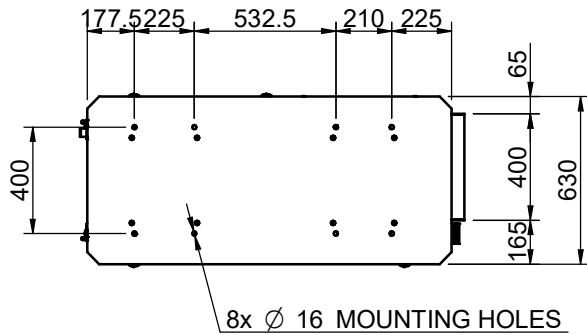

VISTA A

SIPHON BREAK CONNECTIONS (AIR VENT SYSTEM - OPTIONAL KIT)

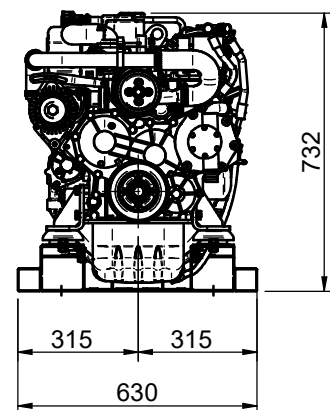
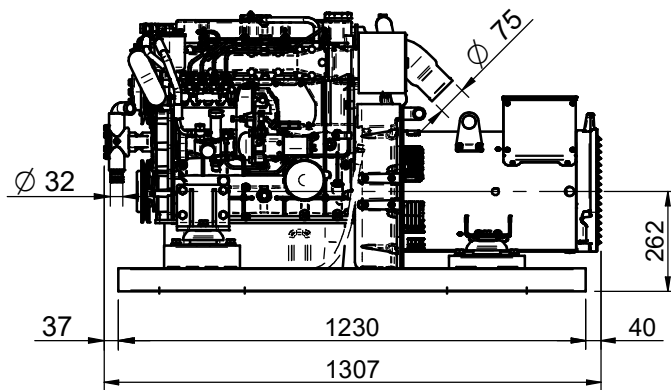
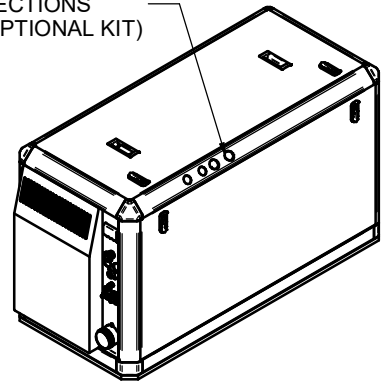

| | | | | | | | |
|-----------------------------|-------|---|-------|------------------------|-----------------|-----------------------------------|-----------------|
| Medidas Nominales (mm) | | GRUPO 35 GT/GTC - 40 GTA/GTAC PARALELO | | | | | |
| Medidas Nominales (mm) | | GENSET 35 GT/GTC - 40 GTA/GTAC PARALLEL | | | | | |
| 100 | a | 300 | ±0.2 | | | | |
| 30 | a | 100 | ±0.15 | ±0.5 | | | |
| 6 | a | 30 | ±0.1 | ±0.3 | ±0.5 | | |
| 0 | a | 6 | ±0.05 | ±0.2 | ±0.5 | ±1.2 | |
| Grado de Precisión DIN-7168 | Fino | Medio | Basto | | | | |
| | ±0.05 | ±0.1 | ±0.2 | | | | |
| | ±0.1 | ±0.2 | ±0.5 | | | | |
| | ±0.2 | ±0.5 | ±1.2 | | | | |
| | | MATERIAL | | ACABADO | TRATAMIENTO | PRESENTACIÓN | ESCALA |
| | | DIBUJADO M. PABLOS | | VERIFICADO P. IGLESIAS | GRADO PRECISIÓN | FECHA CREACIÓN 09/03/2023 | ÚLTIMA REVISIÓN |
| | | | | SOLÉ, S.A. | | FA0714, FA0718, FA1471, FA1472 | |