



www.solediesel.com

Marine generator sets

Operator's manual

60 GSC

U_CTGR60GSC_EN

Introduction



Introduction

Presentation

Dear Customer,

First, we would like to thank you for choosing a Solé Diesel product. We recommend that you read this manual carefully before carrying out any of the operations and keep it close at hand, near the genset, as it can be of great use in the future.

Our goal as a manufacturing company is that you enjoy our product, regardless of the use you make of it. The equipment manufactured in Solé Diesel facilities is designed to offer the highest performance in the most demanding operating conditions.

▲ NOTICE

The images, text and information contained in this manual are based on the product's features at the time of publication. Solé Diesel reserves the right to modify this document without prior notice

Table of contents

Table of contents

| | |
|---|----|
| Introduction..... | 2 |
| Table of contents..... | 3 |
| Safety precautions and instructions..... | 6 |
| Solé Diesel warranty..... | 10 |
| Section 1 – Genset information | 13 |
| 1.1. Genset identification..... | 13 |
| 1.2. Genset parts identification | 14 |
| Section 2 – Transport, handling and storage | 15 |
| 2.1 Reception | 15 |
| 2.2 Transporting and handling the packed genset | 15 |
| 2.3 Transporting and handling the unpacked genset | 16 |
| 2.4 Storage of packed and unpacked genset..... | 16 |
| Section 3 – Installation | 17 |
| 3.1 Angle of installation | 17 |
| 3.2 Genset information | 17 |
| Section 4 - Operation..... | 18 |
| 4.1 Prestart checklist | 18 |
| 4.2 Genset Operation at low temperatures | 18 |
| 4.3 Winterzation and preservation | 19 |
| 4.4 Maintenance during the storage..... | 20 |
| 4.5 Restoration of operational conditions | 20 |
| Section 5 – Systems and scheduled maintenance..... | 21 |
| 5.1. Operating description | 21 |
| 5.2. Periodic maintenance schedule..... | 21 |
| 5.3. General | 23 |
| Maintenance task. Screw tightening, fastening | 23 |
| Maintenance task. Valve clearance inspection | 23 |
| Maintenance task. Compression pressure inspection | 24 |
| 5.4. Lubrication system..... | 25 |
| Circuit description..... | 25 |
| Oil specifications | 25 |
| Maintenance task. Oil filter change..... | 26 |
| Maintenance task. Oil level check..... | 26 |

Table of contents

| | |
|--|----|
| Maintenance task. Oil fill/change | 26 |
| 5.5. Fuel system | 27 |
| Circuit description..... | 27 |
| Fuel specifications..... | 27 |
| Maintenance task. Fuel level inspection..... | 27 |
| Maintenance task. Fuel tank clean | 28 |
| Maintenance task. Water separator filter purge | 28 |
| Maintenance task. Fuel filter change..... | 28 |
| Maintenance task. Injection pump inspection..... | 28 |
| Maintenance task. Injector inspection | 28 |
| 5.6. Cooling system | 29 |
| Coolant specifications | 29 |
| Maintenance task. Coolant check | 30 |
| Maintenance task. Coolant fill/change | 30 |
| Maintenance task. Seawater filter inspection | 30 |
| Maintenance task. Seawater pump impeller inspection..... | 31 |
| Maintenance task. Zinc anode inspection | 31 |
| 5.7. Inlet and exhaust system..... | 32 |
| Exhaust circuit description..... | 32 |
| Maintenance task. Air filter inspection | 33 |
| Maintenance task. Exhaust gas, noise and vibrations inspection | 33 |
| 5.8. Electrical system | 34 |
| Genset control panel | 34 |
| Battery..... | 34 |
| Circuit protection | 34 |
| Maintenance task. Starter motor inspection | 34 |
| Maintenance task. Alternator belt tension inspection | 35 |
| Maintenance task. Battery level | 35 |
| 5.9. Alternator..... | 36 |
| Maintenance task. Control of windings and electrical insulation..... | 36 |
| Maintenance task. Control of bearings | 36 |
| Maintenance task. Cleaning and lubrication | 36 |
| Section 6 – Troubleshooting..... | 37 |
| Section 7 – Technical specifications..... | 43 |
| Section 8 – Tightening torques | 45 |



Table of contents

| | |
|---|----|
| Section 9 – Technical appendices | 46 |
| 9.1. Wiring diagrams | 46 |
| 9.2. Alternator connections..... | 48 |
| Connection Type 1:..... | 48 |
| Connection type 2:..... | 49 |
| Connection type 3:..... | 50 |
| 9.3. Regulator connections..... | 51 |
| Connection type 1:..... | 51 |
| Connection Type 2:..... | 51 |
| Connection Type 3:..... | 52 |
| 9.4. Overall dimensions | 53 |
| Section 10 – Instructions to replace and remove | 55 |
| Section 11 – Inspection prior to the delivery of generator sets | 57 |
| Section 12 - Maintenance log..... | 59 |

Safety precautions and instructions



Safety precautions and instructions

Solé Diesel is concerned for your safety and your machine's condition. Safety Precautions and Instructions are one of the primary ways to call your attention to the potential hazards associated with our engine operation. Follow the precautions listed throughout the manual before and during operation and maintenance procedures for your safety, the safety of others and the performance of your engine.

Types of Safety Precautions:

⚠ WARNING

Indicates the presence of a hazard that can **cause severe personal injuries, death or substantial property damages.**

⚠ CAUTION

Indicates the presence of a hazard that **will or can cause minor personal injury or property damages.**

⚠ NOTICE

Communicates installation, operation and maintenance information that is safety related but not hazard related.

⚠ WARNING

Servicing the fuel system and combustible materials. A flash fire can cause severe injury or death.



Do not smoke or permit flames or sparks near the fuel injection system, fuel line, fuel filter, fuel pump, or other potential sources of spilled fuels or fuel vapors. Never add fuel to the tank while the engine is running because spilled fuel may ignite on contact with hot parts or from sparks.

Catch fuels in an approved container when removing the fuel line or fuel system. Keep the fuel lines and connections tight and in good condition. Do not replace flexible fuel lines with rigid lines and use flexible sections to avoid fuel line breakage caused by vibrations.

Keep the compartment and the engine clean and free of debris to minimize the risk of fire.



Servicing the air cleaner. A sudden backfire can cause severe injury or death.

Do not operate the engine with the air cleaner/silencer removed.

⚠ WARNING



Combustible materials. A fire can cause severe injury or death.

Engine fuels, fuel vapours and combustible materials are flammable and explosive. Handle these materials carefully to minimize the risk of fire or explosion. Equip the compartment or nearby area with a fully charged fire extinguisher.

⚠ WARNING

In case of fire do not open sound shield compartment and follow these instructions:

- Shut down engine(s)
- Continuously discharge entire contents of a halon or CO2 portable fire extinguisher (or other provision) immediately.

Safety precautions and instructions



⚠ WARNING

Carbon monoxide (CO) can cause severe nausea, fainting or death.

Engine exhaust gases contains carbon monoxide gas. Carbon monoxide is an odourless, colourless, tasteless, no irritating gas that can cause death if inhaled for even a short time.

Get fresh air and do not sit, lie down or fall asleep if anyone shows signs of carbon monoxide poisoning:

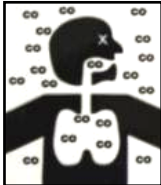

Light-headedness, dizziness

Physical fatigue, weakness in joints and muscles. Sleepiness, mental fatigue, inability to concentrate or speak clearly, blurred vision. Stomachache, vomiting, nausea.

⚠ WARNING

Keep the area around the battery well ventilated. While the engine is running or the battery is charging, hydrogen gas is produced which can be easily ignited.



Never allow battery fluid (battery contains sulfuric acid) to come in contact with clothing, skin or eyes. Always wear safety gloves and protective clothing when servicing the battery. If battery fluid contacts the eyes and/or skin, immediately flush the affected area with a large amount of clean water and obtain prompt medical treatment.

⚠ CAUTION

Before working on the engine or connected equipment, disable the engine as follows:



Set the engine controller to OFF Mode.

- (1) Disconnect the power input from battery.
- (2) Disconnect the battery cables. Remove the negative (-) lead first when disconnecting the battery. Reconnect the negative (-) lead last when reconnecting the battery.

Follow these precautions to prevent the starting of the engine by engine controller, remote start/stop switch, or engine start command from a remote computer.

⚠ CAUTION



Never remove the cooler cap if the engine is hot. Steam and hot engine coolant will spurt out and seriously burn you. Allow the engine to cool down before you attempt to remove the cooler cap.

⚠ NOTICE

Read the engine operator's manual and understand it before operation and maintenance of the engine, to ensure that it continues operating practices and maintenance procedures.

Hearing protection. Use to avoid hearing loss when handling the motor.

Safety precautions and instructions



NOTICE

1. The installer / operator of the engine has to wear suitable CLOTHING for the workplace and the situation; in particular, avoid loose clothes, chains, bracelets, rings and all accessories that could become entangled with moving parts.
2. The installer / operator of the engine has to wear personal protective equipment such as gloves, work shoes, eye and hearing protection as required by the task.
3. The area in which the operator is working has to be kept tidy and free of oil and other liquid spillages and solid waste (metal chips, etc.).

Engine labels

CAUTION - AVISO

Over cranking can cause engine water ingestion.

Excesivos intentos de arranque pueden provocar entrada de agua en el motor.

If the engine does not start after several attempts to crank may cause water entering the engine. In this situation it is recommended:

- 1) Close the seacock.
- 2) Drain the water from the exhaust system in the water trap.
- 3) Do not try to restart the engine until the cause of the start fail is identified.

AVISO

El motor y/o el inversor se suministran sin ningún fluido en su interior. Consulte el manual para seguir el procedimiento de instalación y puesta en marcha.



The engine and the gearbox are supplied without any fluid inside. Consult the manual to follow the installation procedure and commissioning as well as the fluid capacity - coolant, oil and oil of gearbox.

Moving parts. Keep hands, feet, hair, clothing and test leads away from the belts and pulleys when the engine is running. Replace guards, screens and covers before operating the engine.

WARNING

ROTATING PARTS
Can cause severe injury

Do not operate generator set without all guards, screens or covers in place.

CAUTION - AVISO - ATTENTION
ATTENZIONE - ACHTUNG

Read the engine operator's manual and understand it before any operation and maintenance of the engine, to ensure that it continues operating practices and maintenance procedures insurance.

Dangerous voltage. Operate the engine only when all guards and electrical panels are ready.

Safety precautions and instructions



Hot parts, coolant and steam. Stop the engine and let it cool down before touching or removing any engine part.

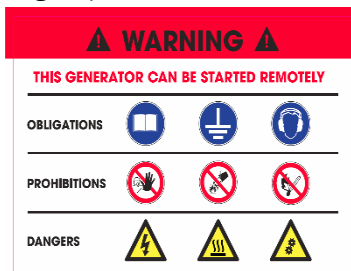

Moving parts. Keep hands, feet, hair, clothing and test leads away from the belts and pulleys when the engine is running. Replace guards, screens and covers before operating the engine.

Heavy material. Engine is a heavy element, use the right tools for transportation and handling.

Do not use the motor as a step. Use it as a step can cause engine damage plus cause undesired operation.



Connection point of the battery cables to the engine. Red cable (positive) and black cable (negative)

⚠ NOTICE

Engine exhaust line installation label, above and below the waterline. See 6.7. Intake and exhaust system.

Solé Diesel Warranty



Solé Diesel warranty

Read the manual and documents delivered with each engine before carrying out any of the operations or presenting any queries. The engine is supplied without any liquids. Ensure that the liquids used match the specifications contained in Solé Diesel manuals.

The application of the conditions described in this document shall only be effective for engines or generator sets that have been invoiced after January 1, 2012.

Solé diesel limited warranty

Solé Diesel guarantees that at the time of shipment all its engines and generator sets comply with the provided specifications and do not have any manufacturing defects.

The limited warranty provided by Solé Diesel enters into force from the time of sale to the first end-purchaser or user of the engine or generator set. In the event that the product is not immediately delivered to the end-customer, the warranty shall enter into force 6 months after the date of sale. Any limited warranty period that has not elapsed can be transferred to the following purchaser (s).

Unless authorised otherwise by Solé Diesel, the warranty periods are applied according to the time elapsed in months from the date of purchase or the limit of hours of operation (whichever occurs first) listed in the following table:

| Limited Warranty Coverage Periods | | | | |
|-----------------------------------|----------|-------|--------|-------|
| Product | Pleasure | | Work | |
| | Months | Hours | Months | Hours |
| Propulsion Engines | 36 | 1000 | 12 | 2000 |
| Generator Sets | 36 | 1000 | 12 | 2000 |

Solé Diesel extended warranty

Solé Diesel an extended period of coverage for the following components: engine block, cylinder head, crankshaft, camshaft, flywheel housing, timing gear housing, timing gear, conrod.

| Extended Coverage Periods | | | | |
|---------------------------|----------|-------|--------|-------|
| Product | Pleasure | | Work | |
| | Months | Hours | Months | Hours |
| Propulsion Engines | 24 | 1500 | - | - |
| Generator Sets | 24 | 1000 | - | - |

Sole Diesel Warranty



Restrictions

Coverage:

- a) To validate the warranty is necessary fill and send the inspection prior to the delivery of propulsion engines or genset to Solé Diesel through an official installer. See SECTION 13.
- b) The warranty covers any failure of the product under normal operating conditions caused by a defect in manufacturing.
- c) The warranty covers the labour costs necessary to replace and/or repair the defective original components, according to Solé Diesel standards of excellence. The time period covered for these operations is limited to 4 hours.
- d) The warranty covers reasonable costs of travel required to carry out the necessary operations. The travel distance is limited to 300 kilometers in conjunction to a travel time of 3 hours.

Excluded from coverage:

- a) If Solé Diesel products are installed and used alongside other products not designed or manufactured by Solé Diesel that affect their operation, the warranty shall apply exclusively to the Solé Diesel products and shall not apply if the products from another manufacturer are inappropriate for use alongside Solé Diesel products or are the cause of the failure or poor operation of our products.
- b) The warranty doesn't will be effective if don't filled correctly and send the inspection prior to the delivery of propulsion engines and genset to Solé through an official installer. SECTION 13.
- c) The warranty shall not apply if the revisions and maintenance services indicated in the User and Maintenance Manuals have not been adhered to properly. In case of implemented warranty, supporting document of the revisions and maintenance service should be exhibited, proving the requirements outlined in the manuals have been followed.
- d) Deterioration resulting from time of storage exceeding 6 months and/or storage conditions that do not comply with the procedures described in the User and Maintenance Manuals.
- e) Deterioration resulting from not complying with the procedure for winter storage while the engine is not in service, as described in the User and Maintenance Manuals.
- f) Faults due to negligence, lack of service, accidents, abnormal use and inadequate service or installation.
- g) Faults due to the use of components not manufactured or sold by Solé Diesel.
- h) Faults due to electrical installations that do not comply with Solé Diesel design specifications or are not expressly approved by Solé Diesel.
- i) Faults due to the use of and operation with fuels, oils or lubricants that are not authorized by Solé Diesel.
- j) Faults due to water entering the cylinder(s) through the exhaust system.
- k) Faults in propulsion engines due to the use of a propeller that is inadequate for the load or application. We recommend contacting Solé Diesel to consult the choice of the correct propeller(s).
- l) Failure for general omission of the procedures described in the User and Maintenance Manuals.
- m) Components subjected to normal operating wear and tear.
- n) Costs due to phone communications, loss of time or money, discomfort, launching, grounding, removal or replacement of vessel parts or materials because the design of the vessel makes it necessary to do so to access the engine, and damage and/or accidents caused as a result of a failure.

Sole Diesel Warranty



Responsibilities

Responsibilities of the manufacturer:

The obligations of Solé Diesel are restricted to repairing the defective parts or, IF DEEMED APPROPRIATE BY SOLÉ DIESEL, returning the amount of the purchase or replacing the parts to prevent poor operation resulting from defective materials or faults in the manufacture covered by the warranty.

Solé Diesel reserves the right to modify the design of any of its products without taking on any obligation to modify a product that has been manufactured previously.

This manual, as well as technical documentation, manuals or pamphlets may undergo modifications without prior notice.

Responsibilities of the purchaser:

The purchaser shall be responsible for the care, operation and maintenance of the product in compliance with the contents of the User and Maintenance Manuals. The purchaser shall provide proof of all the maintenance services performed on the product. The costs of said services and that of the components and liquids replaced during said services shall be at the expense of the purchaser.

The maintenance operations described in this manual shall be performed during the Warranty Contract Periods (Limited and Extended Coverage) by an AUTHORISED SOLÉ DIESEL DEALER. Non-compliance with this condition shall void the warranty in all its terms. In such an event, the materials (oil, filters, etc.) and labour involved shall be at the expense of the purchaser. The purchaser should keep the invoice of the work performed as proof.

If the service is not covered by the warranty, the purchaser must pay for all labour performed, the associated materials and any other expense related to the service.

All shipments of products or components sent by the purchaser for inspection and repair shall be paid in advance by the purchaser.

After-sales service contact

Claims shall be presented during the warranty period to the nearest authorized Solé Diesel dealer (see chart of Solé Diesel Dealers), who shall take care the service covered by the warranty.

The purchaser must provide a proof of purchase and date of purchase by presenting the invoice to the authorized dealer for the purchase of the product served or a copy of it. Claims under warranty shall not be dealt with by the dealer until the date of purchase has been verified.

The following information must also be provided by the purchaser:

- a) Owner's name, address and contact telephone number.
- b) Product model and serial number.
- c) Number of service hours of the product.
- d) Detailed description of the problem.
- e) Information regarding any repair or installation performed by a service not included in the Solé Diesel distribution network, as well as the services performed.

For an updated list of our distribution network, visit Dealers section in our web page www.solediesel.com

Or request this information by contacting Solé Diesel at:

e-mail: info@solediesel.com

Phone: +34 93 775 14 00

Genset information

Section 1 – Genset information

1.1. Genset identification

IDENTIFICATION LABEL:

The nameplate is located above the rocker cover. The characteristics plate of genset it's located above the alternator case.

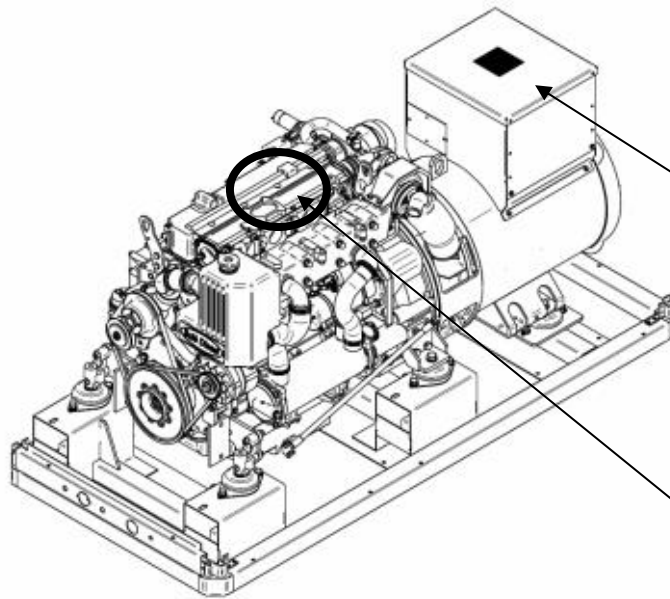

Model: 25 GT S/N: 116027

| | | | |
|---------------------|-----------|-----------------------|--------------------------------------|
| AC Voltage: | 400/230 V | Firing Order: | 1-3-4-2 |
| Amp: | 35.1 A | Oil capacity: | 6.5 L |
| Freq: | 50 Hz | Cool. capacity: | 9.5 L |
| Phase: | 3 PH + N | Oil: | SAE 15W40 |
| Max Power Output: | 19.4 kW | Coolant: | Orgine: 50% 38% Hose diameter: 60 |
| Prime Power Output: | 17.7 kW | RPM: | 1500 |
| DC Voltage: | | Fuel: | DIESEL |
| Insulation: | H | Degree of Protection: | IP 23 |
| No of cylinders: | 4 | Year: | 2020 |
| Bore x Stroke: | 88 X 103 | Weight: | 413 Kg |

REFER TO OPERATOR'S MANUAL FOR MAINTENANCE SPECIFICATIONS AND ADJUSTMENTS

| | | |
|---------------------|--------|----------------------|
| Solé Diesel | | MADE IN SPAIN |
| TIPO TYPE | | |
| MOTOR N° ENG No. | | |
| kw | R.P.M. | |

The characteristics plate of canopy genset it's located outside, as shown in the following picture:

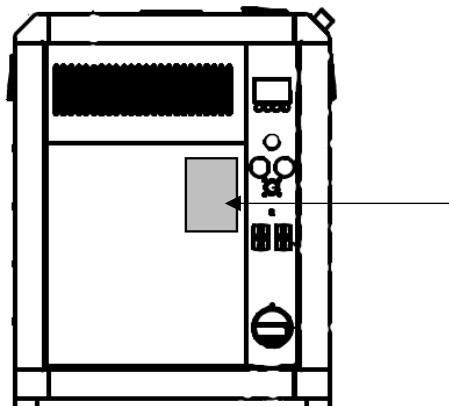

GENSET SERIAL NUMBER:

In addition, all gensets are marked with the serial number on the block, on the fuel injection pump.

Genset information



1.2. Genset parts identification

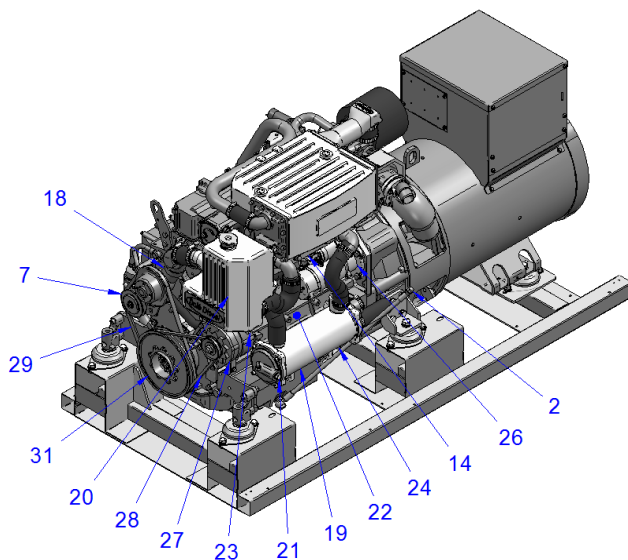
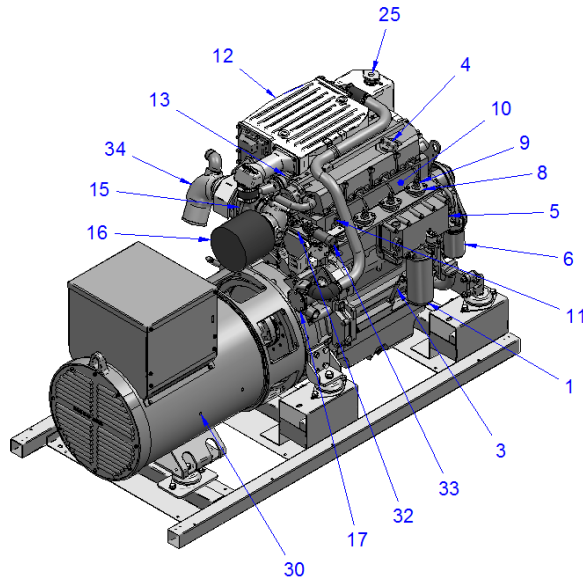

| PIECE | ELEMENT |
|-------|---|
| 1 | Oil filter |
| 2 | Oil drain plug |
| 3 | Dipstick |
| 4 | Oil filler cap |
| 5 | Oil cooler |
| 6 | Fuel filter |
| 7 | Fuel feed pump |
| 8 | Injection pumps |
| 9 | Injectors |
| 10 | Valves |
| 11 | Fuel overflow valve |
| 12 | Air cooled (only in 115 GTC and 120 GTAC) |
| 13 | Admission manifold |
| 14 | Exhaust manifold |
| 15 | Turbocharger |
| 16 | Air filter (only standard version) |
| 17 | Se water pump |
| 18 | Coolant water pump |
| 19 | Heat exchanger |
| 20 | Expansion tank |
| 21 | Anode (anti-corrosion protection) |
| 22 | Coolant drain plug (engine) |
| 23 | Coolant drain plug (expansion tank) |
| 24 | Coolant drain plug (heat exchanger) |
| 25 | Coolant filler cap |
| 26 | Starter motor |
| 27 | Alternator 24V |
| 28 | Alternator belt |
| 29 | Coolant pump and fuel feed pump belt |
| 30 | Vibration damper |
| 31 | Governor |
| 32 | Stop solenoid |

Transporting and handling the unpacked genset



Section 2 – Transport, handling and storage

2.1 Reception

When the genset is delivered make sure that the packing has not been damaged during transport and that it has not been tampered with or that components inside the packing have been removed (see information marked on covers, bases and cartons).

Place the packed genset as close as possible to the place of installation and remove the packing material, checking that the goods supplied correspond to the order specifications.

▲ NOTICE

If you notice damage or missing parts, inform Solé Diesel after-sales departments and the carrier immediately and forward photographic evidence of the damage.

After inspecting the goods if you notice damage, write a reservation on the delivery note. Have the carrier countersign the note and advise Solé Diesel., preferably by mail (info@solediesel.com).

2.2 Transporting and handling the packed genset

When lifting and transporting the genset use EXCLUSIVELY a forklift or bridge crane of appropriate load capacity, with chains equipped with safety hooks suitable for lifting the load.

The use of any other system automatically invalidates the insurance guarantee against possible damage to the genset.

To unpack the genset, you must follow these steps:

1. Remove the cardboard crate.
2. Lift the genset using a forklift and suitable chains, which hook to the genset eyebolts.
3. Transfer the genset to the intended position of installation.
4. Remove the wooden base.
5. Begin installation operations.



Transporting and handling the unpacked genset



2.3 Transporting and handling the unpacked genset

When the genset is unpacked and ready for transport, use EXCLUSIVELY the appropriate lifting eyebolts.

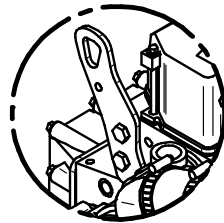
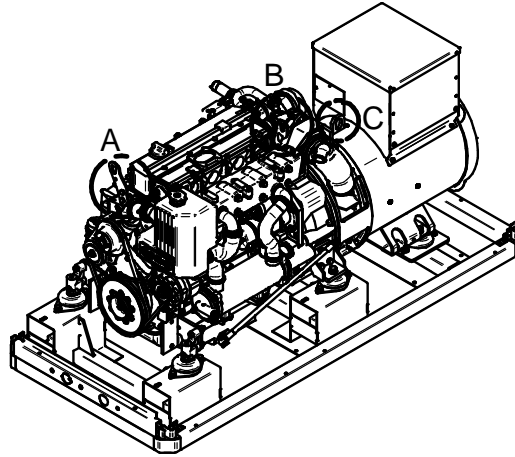

DETALLE A

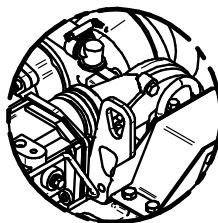

DETALLE B

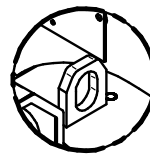

DETALLE C

2.4 Storage of packed and unpacked genset

If the genset is left idle for prolonged periods, the client must check the possible conditions of conservation in relation to the place of storage.

If the genset is unused for prolonged periods and stored, observe all the relative technical specifications.

The treatment of the genset for storage is guaranteed for 6 months after the time of delivery.

▲ NOTICE

If the user decides to start the genset after a long-time period, this must be done in the presence of an authorized technic.

Installation

Section 3 – Installation

3.1 Angle of installation

Make sure the genset is installed on a level surface. Otherwise, the following angular operation maximum is permitted:

| | |
|--------|-------------------|
| | Continuous |
| 60 GSC | 10° |

If the genset operates in these conditions, check Section 5.4. Lubrication System.

3.2 Genset information

Follow these steps to install the genset:

1. FIX GENSET. See 9.4 Genset Dimensions (mounting holes) and Section 8 - Tightening Torques.
2. CONNECT EXHAUST OUTLET. See 9.4 Genset Dimensions.
 1. WET EXHAUST OUTLET
 2. DRY EXHAUST OUTLET + SEAWATER OUTLET
3. CONNECT SIPHON BREAKER. (if installed) See 9.4 Genset Dimensions.
4. CONNECT SEAWATER INLET. See 9.4 Genset Dimensions.
5. CONNECT FUEL INLET. See 9.4 Genset Dimensions.
6. CONNECT LEAK COOLANT OUTLET. See 9.4 Genset Dimensions.
7. FILL WITH OIL. See 5.4 Lubrication System.
8. FILL WITH COOLANT. See 5.6 Cooling System.
9. CHECK EACH PIPE CONNECTION for oil or coolant leaks.
10. CONNECT TO EARTH. See 5.5 Fuel System.
11. PRIME THE FUEL SYSTEM. See 5.5 Fuel System.
12. CONNECT TO THE CONTROL PANEL. See THE Operator's manual of the control panel.
13. CONNECT TO BATTERY. Follow label battery connection into the genset.

▲ NOTICE

It is necessary to install a waterlock (supplied as accessory) in the exhaust system to avoid water ingestion (See section 5.7).

Section 4 - Operation

4.1 Prestart checklist

Follow these checks and inspections to ensure the correct genset operation. In addition, some checks require verification after unit starts.

AIR CLEANER: Check for a clean and installed air cleaner element to prevent unfiltered air from entering the genset.

AIR INLETS: Check for clean and unobstructed air inlets.

BATTERY: Check for tight battery connections.

COOLANT LEVEL: Check the coolant level according to coolant circuit capacity.

DRIVE BELTS: Check the belt condition and tension of the coolant pump and battery charging alternator belt.

EXHAUST SYSTEM: Check for exhaust leaks and blockages. Check the silencer and piping condition and check for tight exhaust system connections.

Check that the exhaust outlet is unobstructed.

FUEL LEVEL: Check the fuel level and keep the tank(s) full to ensure adequate fuel supply.

OIL LEVEL: Maintain the oil level below dipstick high mark and above dipstick low mark.

OPERATING AREA: Check for obstructions that could block the flow of admission air.

SEAWATER PUMP PRIMING: Prime the seawater pump before initial startup. To prime the pump:

- ✓ Close the seacock.
- ✓ Remove the hose from the seawater-filter outlet.
- ✓ Fill the hose and seawater pump with clean water.
- ✓ Reconnect the hose to the water filter outlet.
- ✓ Open the seacock.

Confirm seawater pump operation on start-up as indicated by water discharge from the exhaust outlet.

4.2 Genset Operation at low temperatures

Whenever the atmospheric temperature drops below zero, the following series of circumstances occur:

- The cooling liquids may freeze.
- The oil becomes thicker.
- There is a drop in the voltage at the battery terminals.
- The inlet air temperature is low and the genset has difficulty in starting.
- The fuel loses fluidity.

To prevent the damage caused by low temperature operation, the genset should be prepared:

1. Use special low temperature coolant or suitable anti-freezing agent concentration.
2. Close the seawater cock, when the genset is stopped. Open the seawater filter cover and start the genset adding a mixture of freshwater and suitable anti-freezing agent concentration (see package labels) until the seawater circuit is filled completely. Stop the genset and replace the seawater filter cover. Before starting the genset again, open the seawater cock.
Repeat this operation whenever the genset is used at temperatures below 0°C.
3. Use oil with suitable quality and viscosity. SAE 15W40 is recommended. Under extreme conditions contact with technical support.
4. Cover battery with an adequate material to protect it against the cold. Check that the battery is fully charged. It is also advisable to use a dielectric spray on the electrical connections.
5. When starting the genset, make sure that the glow plugs become hot enough.
6. If necessary, replace the diesel oil by a specified diesel oil type for low temperatures. The accumulation of impurities in the fuel tank could cause faulty firing.

▲ NOTICE

All gensets not in use are subject to rusting and corrosion of machined surfaces that are not protected with a paint coating. The degree of corrosion depends on meteorological changes and climatic conditions. The following recommendations are therefore of a general nature but they will help prevent or reduce the risk of damage due to rusting.

4.3 Winterzation and preservation

If the boat is not going to be used for a long period of time or during the winter, certain tasks must be carried out to keep it in perfect operating condition. If there is no care, the inside parts can oxidize and cause damage on the genset. When the genset is stored, steps indicated below have to be followed:

1. Clean the outer surface of the genset.
2. Bleed the seawater circuit by filling it with fresh water. Fill the seawater circuit again with a mixture of fresh water and anti-freezing agent.
3. Remove the impeller from the seawater pump, clean it with fresh water and store it in place protected from moisture and sunlight.
4. Renew and refill the heat exchanger to the maximum level with a mixture of fresh water and anti-freezing agent.
5. Renew the oil and oil filter in the genset.
6. Cover the air intake.
7. If the fuel tank is small, empty it completely and clean it; fill it up again with a mixture of diesel and anti-corrosion additive. Solé S.A. recommends DIECYL PLUS. Add one measure of this additive for every 25 litres of diesel. On the other hand, if the fuel tank is large, add 1 litre of this additive for every 500 litres of diesel.
8. Clean and dry the area where the genset is installed.
9. Loosen the belts.
10. Apply dielectric spray on the electrical connection, disassemble the battery and charge it several times during the time it is not being used.
11. Apply moisture repellent spray on the motor.

4.4 Maintenance during the storage

During the long genset storage, it has to be stored inside a ventilated area and free of humidity.

When the genset stay stopped for 3 months or more, inside parts can be oxidize and lost the oil film. As a result, the genset could to size up after the storage. To avoid this, the genset must work periodically during the storage.

Realize the following steps at least once per month:

1. In case that has a battery next to the genset, check the electrolyte level and fill it.
2. Start the genset during approximately 10 seconds.
3. Stop the genset during 1 minute. Repeat this action two or three times.
4. Be sure that oil pressure of the genset increase.
5. Get the genset work during 5 or 10 minutes without load, as maintenance operation.

4.5 Restoration of operational conditions

When starting up the genset again after winter lay-up, certain operations must be performed. Follow these steps:

1. Fill the fuel tank with clean diesel. The mixture of diesel oil and anti-corrosion additive in tank for winter lay-up can be used to operate the genset.
2. Get the genset work during 5 or 10 minutes without load, as maintenance operation.
3. Check the fuel filter. If the filter is clogged, replace the filter.
4. Renew the oil in the genset.
5. Check the condition of coolant circuit's rubber hoses.
6. Reconnect the battery and apply a layer of neutral Vaseline to the battery terminals.
7. Remove the nozzle supports and clean them. If possible, verify the setting of the nozzles at a workshop. Then install the clean nozzles.
8. Connect the cooling and exhaust system. Open the seawater cock.
9. Verify whether there are any leaks in the fuel, coolant and oil systems.

Section 5 – Systems and scheduled maintenance

5.1. Operating description

Information of special tools required and basic safety precautions.

Disassembly:

- ✓ Use the correct tools and instruments. Serious injury or damage to the genset can result from using the wrong tools and instruments.
- ✓ Use an overhaul stand or work bench if necessary. Also, use assembly bins to keep the genset parts in order of removal.
- ✓ Lay down disassembled or cleaned parts in the order in which they were removed. This will save you time at reassembly.
- ✓ Pay attention to the marks on assemblies, components and parts for positions or directions. Put on your own marks, if necessary, to aid reassembly.
- ✓ Carefully check each part for faults during removal or cleaning. Signs of abnormal wear will tell if parts or assemblies are functioning improperly.
- ✓ When lifting or carrying heavy parts, get someone to help you if the part is too awkward for one person to handle. Use jacks and chain blocks when necessary.

Reassembly:

- ✓ Wash all genset parts, except oil seals, O-rings, rubber seals, etc. in cleaning solvent and dry them.
- ✓ Use only the correct tools and instruments.
- ✓ Use only good quality lubricating oils and greases. Be sure to apply a coat of oil, grease, or sealant to parts as specified.
- ✓ Use a torque wrench to tighten parts when specified tightening torques is required.
- ✓ Replace all gaskets and packing. Apply appropriate amount of adhesive or liquid gasket when required.

▲ NOTICE

- ✓ Increase the frequency of maintenance in harsh duty conditions (frequent stops and starts, dusty surrounding, prolonged winter season, no-load running).
- ✓ Risk of burns during maintenance operations carried out when the genset is hot. Wear suitable safety clothing.
- ✓ It is strictly forbidden to clean the genset with compressed air.
- ✓ It is strictly forbidden to perform maintenance/cleaning operations in the presence of moving parts.
- ✓ Use gloves, overalls, etc. to protect the body from burns.

5.2. Periodic maintenance schedule

The maintenance and fault diagnostic procedures involve risks that may cause severe injury or even death. These procedures should therefore be carried out solely by qualified electrical and mechanical specialists. Before any maintenance and cleaning work, make sure that there are no moving parts, that the generator housing has cooled to ambient temperature, that the electricity generating set cannot be accidentally started up and that all procedures are strictly observed.

Systems and scheduled maintenance



| | Inspection Item | Intervals | | | | | | | Winter storage and Preservation |
|----------------------------|--|-----------|-------------|------------|------------|------------|------------|---------------|---------------------------------|
| | | Daily | 1st 20h-50h | Every 200h | Every 400h | Every 800h | Every year | Every 2 years | |
| General | Screw tightening, fastening. | | I | | I | | | | |
| | Engine block. | | | | | | | | CL |
| | Valve clearance. | | | | I | | | | |
| | Exhaust gas, noise and vibrations. | I | | | | | | | |
| | Compression pressure. | | | | | I | | | |
| Lubrication system* | Genset oil. | I | C | C | | | C | | C |
| | Oil filter. | | C | C | | | | | |
| Fuel System | Fuel level. | I | | | | | | | |
| | Fuel tank. | | | | | | | CL | |
| | Fuel filter. | | | | C | | | | E/CL/I |
| | Water separator filter (if applicable). | | E | | C | | | | |
| | Injection pump. | | | | | I | | | |
| | Injector. | | | | | I | | | |
| Cooling system | Purge the feed system. | | | | | | | I | |
| | Coolant. | I | | | | | | C | C |
| | Sea water circuit | | | | | | | | I/CL |
| | Water filter | I | CL | CL | | | | | |
| | Sea water cock | I | | | | | | | |
| | Sea water pump impeller. | | | I/C | I | | | | I/CL |
| Intake system | Anode | | | I/C | | | | | |
| | Air filter. | | I | | C | | | C | I |
| Electrical system | Instruments. | I | | | | | | | |
| | Starter and alternator. | | | | I | | | | |
| | Belt. | | I | | I | C | | | I |
| | Battery level | | I | I | | C | | | |
| | Main alternator - electrical insulation. | | | | | I | | | I |

* Use oil with 15W40 viscosity and no less than ACEA E5 or API CH-4/SJ quality.

I: Inspect, adjust or fill. E: Empty. C: Change. CL: Clean.

5.3. General

Solé Diesel offers, for these engine models, the several Pack, consult on the web.

- Welcome pack.
- On board pack.
- Maintenance pack 50 hours.
- Maintenance pack 1600 hours.
- Maintenance pack 3000 hours.



Maintenance task. Screw tightening, fastening

For details of tightening torques see Section 9 - Torques.

Maintenance task. Valve clearance inspection

The rocker cover must be dismantled to check the valve clearance. This operation must be carried out when the genset is cold.

| Item | | Assembly standard |
|--------------------------------|------------------|-------------------|
| Valve clearance (cold setting) | Inlet Exhaust | 0,3 mm |

Inspection

1. Insert the appropriate thickness gauge between the rocker arm and valve cap to check the clearance.
2. Loosen the rocker nut (1).
3. Tighten or loosen adjusting screw (2) to adjust valve clearance by checking thickness with thickness gauge (3).
4. When you have adjusted the thickness, tighten the rocker nut and recheck the thickness.

With piston n° 1 in the top dead centre of the compression cycle, adjust the play of the intake and exhaust valves of cylinder n° 1. Proceed similarly as with the other cylinders. The position of the BTDC can be confirmed with the lining signs of the distribution or timing cover and the crankshaft pulley.

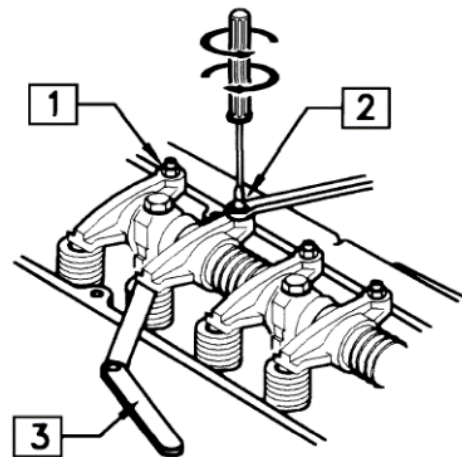

NOTICE

The adjustment of the valve play must be made after the cylinder head screws are again tightened. (Strictly comply with the operation sequence indicated in the section 9 - Torques).

Systems and scheduled maintenance



Maintenance task. Compression pressure inspection

Start by:

1. Make sure the genset oil level, air cleaner, starting motor and battery are well-conditioned.
2. Start the genset and allow it to warm up thoroughly, until 50°C or more coolant temperature.

Measure the compression pressure on all cylinders:

1. Remove the injection nozzle from the cylinder head where the compression pressure is to be measured.
2. Attach the compression pressure gauge.
3. Disconnect the stop solenoid connector (the fuel supply shut off) and crank the genset by means of the starter, and read the compression pressure gauge indication when the genset is running at specified speed.

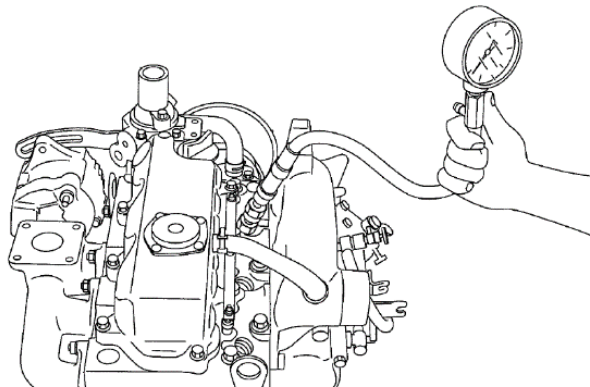

If the compression pressure is lower than repair limit, check the genset parts affected.

| Model | Compression pressure |
|--------|---|
| 60 GSC | 3,0 a 3,8 MPa (30,6 a 38,7 kgf/cm ²) |

NOTICE

- It is not a good practice to measure the compression pressure on only few cylinders, and presume the compression on the remaining cylinders.
- Compression pressure varies with genset speed. Check genset speed when measuring the compression pressure.
- The compression pressure will be slightly higher in a new or overhauled genset due to new piston rings, valve seats, etc.

Systems and scheduled maintenance



5.4. Lubrication system

Circuit description

The lubrication circuit is forced by the trochoid gear pump, and it is composed of the following elements.

| PIECE | ELEMENT |
|-------|-----------------------------------|
| 1 | Oil pan |
| 2 | Aspiration pipe |
| 3 | Oil pump |
| 3(a) | Flow control valve |
| 3(b) | Maximum pressure valve |
| 4 | Oil heat exchanger |
| 5 | Oil filter |
| 6 | Oil pipe |
| 7 | Crankshaft bearing |
| 8 | Connecting rod bearing |
| 9 | Camshaft bearing |
| 10 | Cooling cylinder pipe |
| 11 | Cooling cylinder pipe |
| 12 | Tappet |
| 13 | Pushrod |
| 14 | Rocker arm |
| 15 | Pipe to oil pan |
| 16 | Oil pressure sensor |
| 17 | Pipe to turbocharger |
| 18 | Turbocharger |
| 23 | Pipe to oil pan |
| 24 | Pipe from turbocharger to oil pan |
| 25 | Oil suction pump |

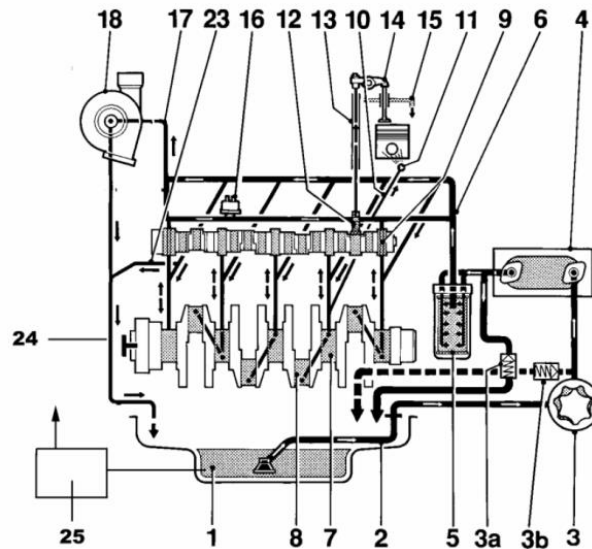

| Model | Oil circuit capacity (L)* |
|--------|---------------------------|
| 60 GSC | 11 |

*Including filter change (0,5l)

The minimum oil pressure in the lubrication circuit is **0,1 kg/cm²**.

Oil specifications

Use oil with 15W40 viscosity (this is an all-season oil for temperatures ranging between -15°C and +40°C) or select the most suitable oil viscosity for the atmospheric temperatures on which the genset is going to be operated. On the other hand, use oil quality no less than ACEA E5/E3 or API CH-4/SJ. Other genset oils may affect warranty coverage, cause internal genset components to seize and/or shorten genset life.

Never mix different types of genset oil. This may adversely affect the lubricating properties of the genset oil.



Systems and scheduled maintenance



Maintenance task. Oil filter change

The oil filter is located under inlet manifold of the genset. Remove oil filter with a belt wrench. When fitting a fresh oil filter, smear a small quantity of oil into the annular seal and firmly tighten it with the hand. When this operation is finished, start the genset and check oil is not leaking.

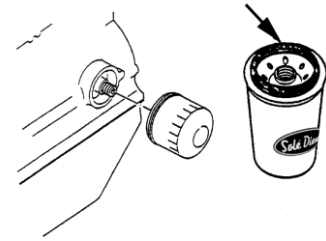

Maintenance task. Oil level check

Check the oil level in the crankcase daily or before each start-up to ensure that the level is between the upper (Max mark) and lower (Min mark) lines on the dipstick. To check the oil level:

1. Remove the dipstick
2. Wipe the dipstick end
3. Reinsert inside the guide
4. Remove it again to see the oil level

If the genset is fitted inclined, the oil dipstick must be modified to avoid problems of aspiration by the oil pump. Follow next steps to perform the modification:

1. With the engine in horizontal position, fill the oil circuit until the dipstick minimum mark and take note of the quantity of oil used.
2. With the engine in horizontal position, fill the oil circuit until the dipstick mark maximum and take note of the quantity of oil used.
3. With the engine inclined, fill the oil circuit with the maximum oil quantity, according to the previous amount

Then, extract the difference between the maximum and minimum quantity, and mark the new minimum.

NOTICE

Do not operate the genset if the oil level is below the Min mark or above the Max mark.

Maintenance task. Oil fill/change

Oil must be changed with hot genset so as to be sure the oil is fully drained. The procedure is the following:

1. Drain the oil (follow steps below)
 - a) Stop the genset.
 - b) Disconnect the battery negative (-) terminal.
 - c) Remove the oil drain plug.
 - d) Connect the external oil pump to the end of the oil drain hose. Place the outlet of the pump into an oil collection container.
 - e) Allow time for the genset oil to drain completely.
2. Replace the oil filter.
3. **Remove dipstick**
4. Fill with oil according to oil capacity circuit.
5. Check for leaks.
6. Check oil level according to the oil level check procedure.

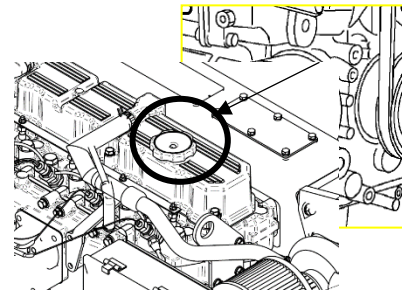

NOTICE

Never overfill. Overfilling may result in white exhaust smoke, genset overspeed or internal damage.

Systems and scheduled maintenance



5.5. Fuel system

Circuit description

The fuel system is based on a fuel feed pump and an in-line mechanical injection pump.

| PIECE | ELEMENT |
|-------|---|
| 1 | Fuel tank (supplied as accessory) |
| 2 | Fuel intake line (supplied as accessory) |
| 3 | Fuel feed pump |
| 4 | Fuel line to fuel filter |
| 5 | Fuel filter |
| 6 | Fuel line to injection pumps |
| 7 | Injection pumps |
| 8 | Fuel high-pressure pipes |
| 9 | Injectors |
| 10 | Fuel return line |
| 11 | Pressure holding valve |
| 12 | Fuel return to tank |
| 14 | Fuel decanting filter (supplied as accessory) |

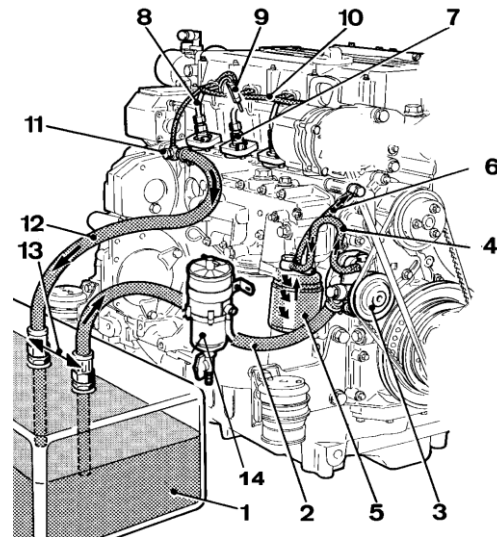

Fuel specifications

Use ASTM diesel fuel No.2-D for the best genset performance, to prevent genset damage. Never use kerosene, heavy diesel fuel or biodiesel. It is essential to use clean and filtered diesel oil.

The use of diesel oil that not complies with the technical specifications may affect warranty coverage and cause serious damage in the injection system and internal genset components.

Maintenance task. Fuel level inspection

Periodically, it is necessary to check the fuel level to assure the operation of the genset. On top of that, if fuel pump sucks air when the fuel level is lower than pump suction, it could break.

Whenever possible, keep the fuel tank full. The temperature changes may cause condensation of the damp air present in the tank and this water accumulates at the bottom. It can cause an increase of corrosion or an impossibility of starting the genset if this water is aspirated by the fuel pump.

Maintenance task. Fuel tank clean

The fuel impurities could obstruct the suction pump. For this reason, drain out the content of the fuel tank to remove condensate and any foreign material. Then, wash the tank with fuel and refill it.

Maintenance task. Water separator filter purge

The fuel system has to have a water separator filter (supplied as accessory) to avoid the inlet of water in the fuel circuit. According to the maintenance plan it is necessary to purge the filter to eliminate water periodically. This is the procedure:

- 1) Loosen the bottom nut to eliminate water.
- 2) Shut it off again.
- 3) Check for any leakage.



Maintenance task. Fuel filter change

Procedure to change the fuel filter:

1. Close the fuel supply valve.
2. Disconnect fuel pipes from the fuel filter.
3. Remove fuel filter with a bell key.
4. Place a new fuel filter.
5. Reconnect fuel pipes from the fuel filter.
6. Open the fuel supply valve.
7. Once finished with this operation, start the genset and check for oil leaks.



CAUTION

Wash hands after any contact with diesel fuel.

Maintenance task. Injection pump inspection

The injection pump is adjusted at factory and should never be adjusted carelessly. Such adjustment, whenever is required, shall be made by a SOLÉ DIESEL licensed service shop, since a precision pump monitor and skill knowledge are required.

You must check:

- The presence of exhaust smoke color.
Procedure: quickly accelerate genset.
Criteria: no remarkably black smoke exhaust, and correct function of fuel cut-off solenoid.
- Any leaks at the body injection pump or fuel lines.

Maintenance task. Injector inspection

This operation requires special tools and must be carried out by a service workshop licensed by Solé Diesel.

Systems and scheduled maintenance



5.6. Cooling system

The genset cooling system is based on coolant circulation controlled by centrifugal pump with thermostatic control and heat exchanger, where the coolant is refrigerated by sea water. Moreover, the exhaust manifold is cooled also by sea water.

Coolant circuit description

| PIECE | ELEMENT |
|-------|-------------------------------|
| 1 | Pump prime line |
| 2 | Coolant pump |
| 3 | Oil cooler |
| 4 | Cylinder cooling circuit |
| 4A | Cylinder heat cooling circuit |
| 5 | Expansion tank |
| 6 | Wet exhaust manifold |
| 7 | Turbocharger |
| 8 | Heat exchanger |
| 9 | Seawater pipe |
| 10 | Wet exhaust elbow |
| 11 | Coolant pump inlet |
| 12 | Thermostat |

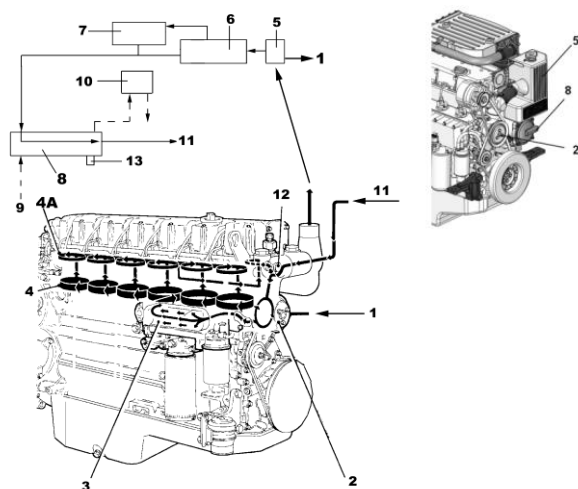

Sea water circuit description

| PIECE | ELEMENT |
|-------|--|
| 1 | Sea water pump |
| 2 | Air cooler (only in 115 GT/GTC and 120 GTA/GTAC) |
| 3 | Heat exchanger |
| 4 | Wet exhaust elbow |

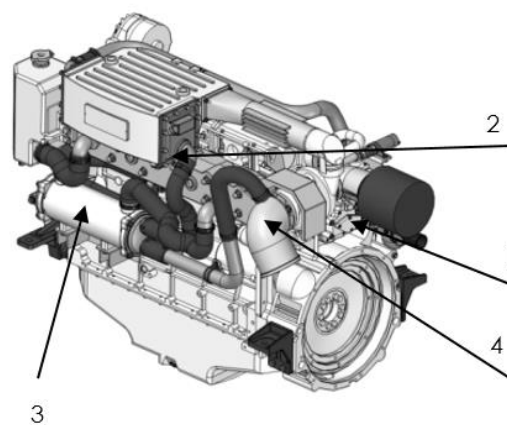

| Model | Coolant circuit capacity (L) |
|--------|------------------------------|
| 60 GSC | 17,5 |

Thermostatic valve

Apertura inicial 83°C

Apertura final 98°C

Coolant specifications

It is recommended use Solé Diesel 50% coolant or another coolant with similar specifications. On the other hand, distilled water with an anti-freezing agent is also suitable. The anti-freezing agent concentration according to operating conditions is specified in anti-freezing agent package labels. It is advisable select the anti-freezing agent concentration based on a temperature approx. 5°C under the actual atmospheric temperature.

Other genset coolants may affect warranty coverage, cause an internal build-up of rust and scale and/or shorten genset life.

NOTICE

Never mix different types of coolants. This may adversely affect the properties of the genset coolant.

Maintenance task. Coolant check

Allow the genset to cool. Release pressure from the cooling system before removing the pressure cap. To release pressure, cover the pressure cap with a thick cloth and then slowly turn the cap counter clockwise. Remove the cap after pressure has been completely released and the genset has cooled. Check the coolant level at the tank, the level must be approximately 3/4 full.

Maintenance task. Coolant fill/change

1. Drain off all the coolant by opening the two drain plugs, one in the heat exchanger and the other in the cylinder block.
2. Close the drain plugs.
3. Remove bleeding bolt of thermostat holder
4. Refill to the hole in the tank cap with coolant

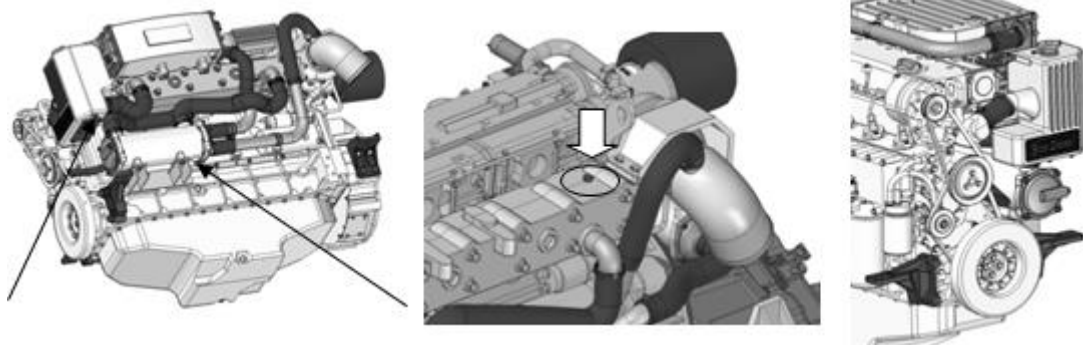

Maintenance task. Seawater filter inspection

It is important to install a seawater filter (supplied as accessory) between seawater cock and the seawater pump to avoid that any impurity might clog the seawater circuit or seawater pump.

To clean this filter:

1. Loose the cover top, turning it.
2. Remove the filtering component and clean it.
3. Fit it again taking care that the cover is well seated on the o-ring.
4. Start the genset to check seawater leakages.



Maintenance task. Seawater pump impeller inspection

Seawater pump impeller is neoprene and cannot rotate dried. If operated without water, the impeller can be broken. It is important therefore that a spare impeller is always available. Impeller inspection and replacement procedure:

1. Close the seawater cock.
2. Remove the seawater pump cover plate.
3. Remove the impeller from the shaft.
4. Clean the housing.
5. Inspect the impeller for damaged, cranked, broken, missing or flattened vanes. The impeller vanes should be straight and flexible.

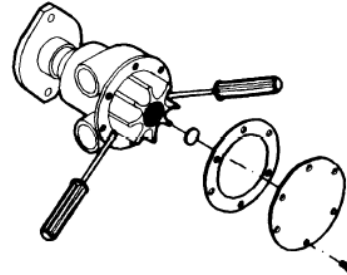

If it is damaged replace with a new one.

6. Lubricate the impeller with soapy water before installation.
7. Install the impeller. During installation push and rotate the impeller in the same direction as the genset rotation until it is thoroughly seated in the impeller housing.
8. Inspect the cover plate and gasket for corrosion and/or damage. Replace components as necessary.
9. Lubricate the gasket with silicon grease and attach the gasket and cover plate to the seawater pump housing.
10. Open the seacock.
11. Start the genset and check for leaks.

Maintenance task. Zinc anode inspection

In order to avoid the corrosion produced by galvanic currents, the genset is fitted with a zinc anode located on the front lid of the coolant-seawater heat exchanger. Anticorrosion zinc anode inspection and replacement:

1. With the genset cooled, close the seacock, open the coolant drain plug and drain the coolant into a suitable container.
2. Remove the anticorrosion zinc anode (plug) from the heat exchanger.
3. Use a wire brush to remove the loose corrosion on the anticorrosion zinc anode.
4. Clean the threaded hole of the heat exchanger and coat the threads of anticorrosion zinc anode. Install the anticorrosion zinc anode into the heat exchanger.
5. Close the coolant drain plug and open the seacock. Refill the coolant circuit.
6. Start the genset and check for leaks at the anticorrosion zinc anode location. The pump is operating if the seawater flows from the exhaust outlet.

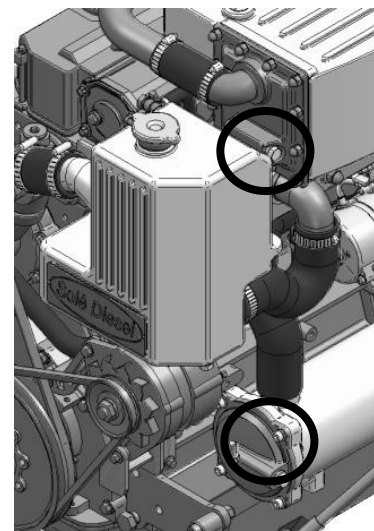

5.7. Inlet and exhaust system

Exhaust circuit description

There are two possible installations of the exhaust system. You need to check the distance between water injection point and waterline to decide which type of installation you need. This information is specified in the following drawings.

The elements included in the drawing are essential for the correct genset operation:

- Waterlock (supplied as accessory) to prevent seawater from entering inside the engine when it stops.

To calculate the required collector capacity, we must follow the following formula:

$$C = \frac{\left(\frac{\pi}{4} D^2 * L\right)}{1000000} * 0.5$$

C = collector capacity (L)

D = Inside diameter of the tube (mm)

L = Tube length (mm)

- Goose neck (supplied as accessory)
- Siphon breaker (supplied as accessory) – needed in case there is less than 150 mm between the water injection point of wet exhaust and the waterline, or if the point of injection is below waterline.

Exhaust backpressure (kPa)

Max - 3

Type 1 installation. When between water injection point of wet exhaust and waterline is minimum 150 mm.

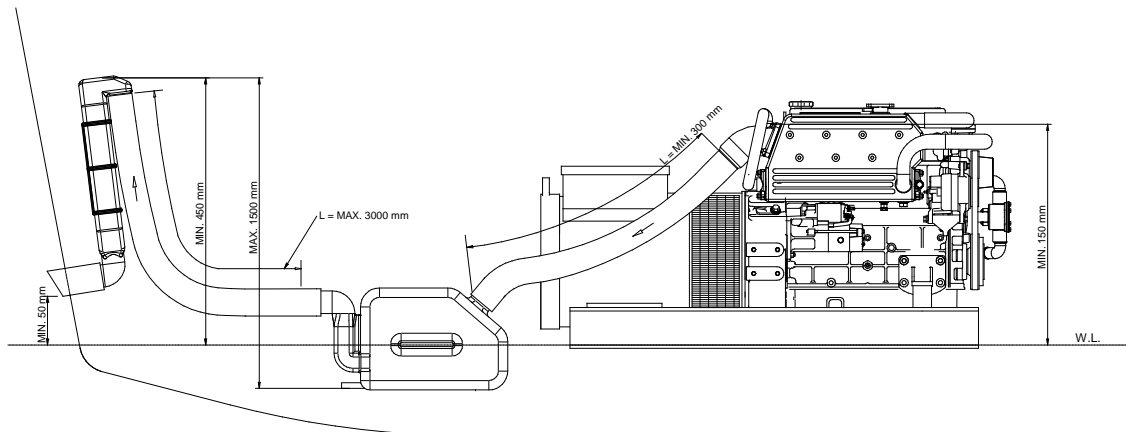

Type 2 installation. When between water injection point of wet exhaust and waterline there is less than 150 mm or the point of injection is below waterline.

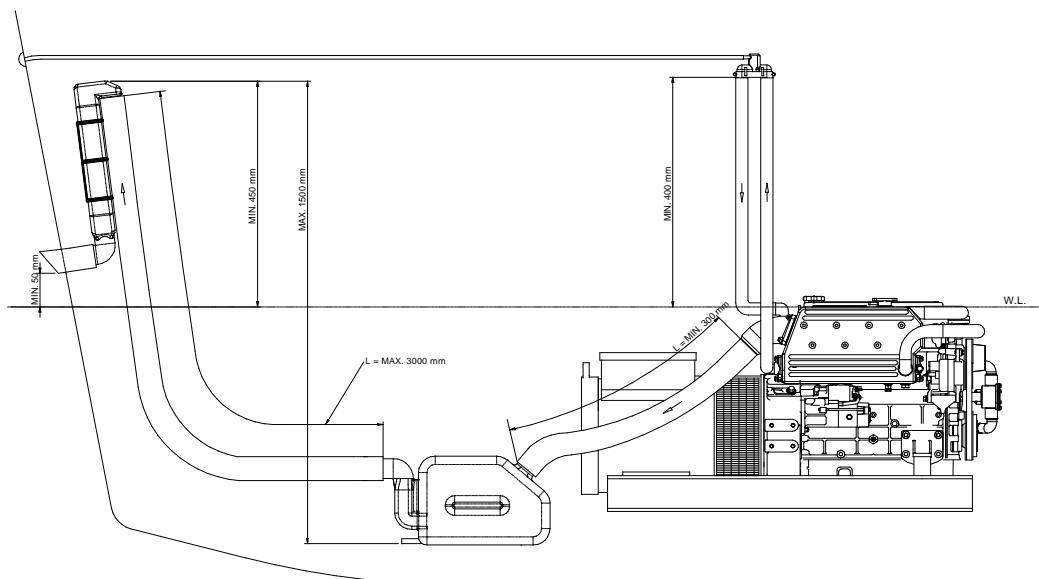

▲ NOTICE

The wet exhaust is the genset's standard equipment. If you want dry exhaust, which is an optional equipment, contact with our dealers.

Maintenance task. Air filter inspection

Genset is provided with an intake air filter. Examine the element and housing for damage. Replace the complete air filter if necessary.

▲ NOTICE

It is important to ensure that the combustion air is freely supplied and freely expelled from the area.

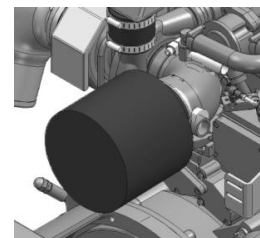

Maintenance task. Exhaust gas, noise and vibrations inspection

Inspect the exhaust system components for cracks, leaks and corrosion.

Exhaust system inspection points

1. Check the hoses for softness, cracks or dents. Replace the hoses as needed.
2. Check for corroded or broken metal parts and replace them as needed.
3. Check for loose, corroded or missing clamps. Tighten or replace the hose clamps and/or hangers as needed.
4. Check that the exhaust outlet is unobstructed.
5. Visually inspect the exhaust system for exhaust leaks. Check for carbon or soot residue on exhaust components. Carbon and soot residue indicate an exhaust leak. Seal leaks as needed.

5.8. Electrical system

Genset control panel

You can find all information regarding the control panel in the Control Panel Operator's Manual.

Battery

The minimum recommended capacity is from 100Ah. However, this value serves as a general reference since it relates to the maximum intensity it can offer for starting the generator set.

The connection of the battery for a standard engine:

- Positive battery is connected to the starter.
- Negative battery is connected to the relay support.

The connection of the battery for an earth isolated engine.

- Positive battery is connected to the starter.
- Negative battery is connected to the bipolar relay.

| Genset model | Battery capacity (Ah) |
|--------------|-----------------------|
| 60 GSC | 100 |

Circuit protection

AC Breaker interrupts the genset output in the event of an overload or short circuit. It is located in front panel as is showed in the section 10.

| Genset model | Intensity (A) |
|--------------|---------------|
| 60 GSC | 400 |

Maintenance task. Starter motor inspection

1. Check if there is any impurity in pinion teeth.
2. Make sure that the pinion shaft turns freely when turned in the direction of driving (clockwise) and it is locked when turned in the opposite direction. If not, replace the overrunning clutch.



Maintenance task. Alternator belt tension inspection

Push the belt inward with thumb pressure exerted midway between the pulleys, as shown, to check the belt tension (deflection). If the tension is incorrect, loosen the adjusting bracket bolt and mounting bolt, and move the alternator in or out.

| Item | Assembly Standard |
|-------------------|-------------------|
| V-belt deflection | 10 - 12 mm |

▲ NOTICE

An excessive tension may cause a quick wear of the belt and alternator bearings. Otherwise, if the belt is excessively loose or has oil and insufficient load, it can cause the belt to skid.

▲ CAUTION

Never adjust the belt tension with genset running or battery connected.

Maintenance task. Battery level

Battery requires a very careful handling and frequent checking. Proceed as shown below:

1. Keep battery dry and cleaned.
2. Check terminal cleanliness regularly. If dust is settled, terminals should be loosened, cleaned and smeared with a neutral grease layer.
3. Metal objects must not be placed over the battery.
4. Add distilled water if the level is out of range.

5.9. Alternator

The maintenance and fault diagnostic procedures involve risks that may cause severe injury or even death. These procedures should therefore be carried out solely by qualified electrical and mechanical specialists. Before any maintenance and cleaning work make sure that there are no live parts that the generator housing has cooled to ambient temperature, that the genset cannot be accidentally started up and that all procedures are strictly observed.

Maintenance task. Control of windings and electrical insulation

The condition of the windings can be checked by measuring their electrical resistance to earth. While running this test, disconnect the voltage regulator. It is usually sufficient to control the main winding.

The readings should give a measurement of the least 1MOhms. If the insulation resistance is below this threshold, the alternator alone should be oven dried at 60 – 80°C for 3 hours. Before carrying out this operation remove the voltage regulator. As an alternative to oven drying hot air at 60 – 80°C can be blown through the alternator for at least 1 hour.

Maintenance task. Control of bearings

During maintenance control the condition of the bearing and check that no grease has leaked: the lifespan of the bearings depends on the vibrations and axial strains they undergo (vibrations can increase considerably with a bad alignment) and on the working conditions. So check for any unusual signs: vibrations, unusual noises.

If undue vibrations or noises appear after long-term usage, these could be due to a worn bearing that, if damaged, has to be replaced. No maintenance is required for the total operating time:

| Operating time |
|----------------|
| 20.000 horas |

▲ NOTICE

A bearing lifespan is closely linked to the working conditions and environment.

Long periods of sustained vibrations can damage the bearing balls and their seat. Too high humidity can emulsify the grease and encourage corrosion.

Intense vibrations caused by the motor or bad alignment of the components in the genset put the bearing under stresses that will reduce its lifespan.

Maintenance task. Cleaning and lubrication

Any kind of cleaning work must be carried out with the genset shutdown and the mains power shut off for the risk of severe hazard for persons and objects. Moreover, prior to approaching or touching the alternator, ensure that it is at room temperature.

Make sure that the genset is shut down and the mains power is shut off before cleaning the outside of the genset with compressed air.

Never and for no reason whatsoever use fluids or water. Do not use compressed air to clean internal electrical parts since this could cause short circuits or related problems.

Section 6 – Troubleshooting

If a fault occurs in the genset, proceed as follows:

- ❖ Within the period of warranty:
 - Contact to Sole Diesel Official Service. See Solé Diesel warranty.
- ❖ Outside the period of warranty:
 - Contact to Sole Diesel Official Service. See Solé Diesel warranty.
 - Stop the genset, determine the cause and repair it before continuing driving the motor.

Troubleshooting



| GENSET FAILURE | SYSTEM | PROBABLE CAUSES | RECOMMENDED ACTIONS |
|-----------------------------------|---------------------------------------|---|---|
| MANUAL START FAILURE | ELECTRICAL SYSTEM (CC) | Power cable fuse (red). | Replace the fuse in the installation. If fuse blows again, check electrical system for overloads or short circuits. |
| | | Discharged or empty battery. | Charge the battery or replace it with a new one. |
| | | Loose or corroded battery connections. | Check the battery connections are correct, clean and tight. |
| | | Faulty start/preheating relay. | Check and replace the preheating/start relay if necessary. |
| | | Faulty starter motor | Check starter motor and replace it if necessary. |
| | | Control panel start signal | Check the start signal from the controller (pink wire). |
| | GENERAL | Low compression pressure. | Check the compression of each cylinder. |
| | LUBRICATION SYSTEM | Oil viscosity too high. | Check oil viscosity (according to Technical Specifications). |
| | FUEL SYSTEM | Faulty or clogged fuel pump. | Check the pump by verifying the fuel inlet and outlet of the pump. Replace it with a new one if necessary. |
| | | Clogged fuel pipes | Check fuel pipes. |
| Clogged fuel filter | | Replace fuel filter. | |
| Faulty injection pump | | Contact an Official Solé Diesel Service. | |
| Air in fuel system | | Bleed fuel system. | |
| Dirty or faulty fuel injectors | | Clean, test and/or replace fuel injector which is not operating properly. | |
| Fuel injection timing malfunction | | Adjust fuel injection timing | |
| INLET AND EXHAUST SYSTEM | Empty fuel tank or closed fuel valve. | Add fuel and place fuel valve in open position. | |
| | Dirty or clogged fuel tank. | Clean tank with proper products. | |
| | | Dirty or clogged air filter. | Replace the air filter element. |

Troubleshooting



| GENSET FAILURE | SYSTEM | PROBABLE CAUSES | RECOMMENDED ACTIONS |
|--|---|---|---|
| STARTS AND THEN STOPS | GENERAL | The fuel regulator is not operational. | Contact an Official Solé Diesel Service. |
| | FUEL SYSTEM | Faulty or clogged fuel pump | Check fuel pump inlet. |
| | | Clogged fuel filter | Replace fuel filter. |
| | | Air in fuel system | Bleed fuel system. |
| | | Incorrect injection pump setting | Contact an Official Solé Diesel Service. |
| Closed fuel outlet tap | Open the fuel outlet tap. | | |
| COOLING SYSTEM | Low cooling liquid level. | Check cooling liquid level and fill tank if necessary. | |
| ELECTRICAL SYSTEM (CC) | Faulty stop solenoid (ETR). | Check stop solenoid and replace it if necessary. | |
| | Pressed emergency stop button. | Reset the emergency stop button position. | |
| INLET AND EXHAUST SYSTEM | Control panel start signal. | Check the start signal from the controller (yellow wire). | |
| | Dirty or clogged air filter. | Replace the air filter element. | |
| BLACK SMOKE | FUEL SYSTEM | Clogged fuel filter. | Replace fuel filter. |
| | | Dirty or faulty fuel injectors. | Clean, test and/or replace fuel injector which is not operating properly. |
| | | Incorrect injection pump setting. | Contact an Official Solé Diesel Service. |
| INLET AND EXHAUST SYSTEM | Clogged air filter. | Replace the air filter element. | |
| BLUE SMOKE | GENERAL | Incorrect valve clearance. | Perform valve adjustment. |
| | LUBRICATION SYSTEM | Oil level too high. | Check the lubrication oil level and reset it. |
| LOW OIL PRESSURE | LUBRICATION SYSTEM | Faulty oil pump. | Contact our dealer |
| | | Strangled oil pressure-relief valve. | Clean the valve and check its operation. |
| | | Oil pressure too low. | Check oil level. |
| | | Oil level too low. | Reset oil level. Inspect the marine generator set for leaks. |
| | | Faulty oil pressure valve. | Contact an Official Solé Diesel Service. |
| Faulty pressure gauge, pressure sensor and/or pressure switch. | Check and/or replace elements. | | |
| Engine tilt above allowable values. | Check the engine installation inclination. Reinstall the engine if necessary. | | |

Troubleshooting



| GENSET FAILURE | SYSTEM | PROBABLE CAUSES | RECOMMENDED ACTIONS |
|-------------------------------|---------------------------------|---|--|
| OIL PRESSURE TOO HIGH. | LUBRICATION SYSTEM | Strangled oil pressure-relief valve | Clean the valve and check its operation. |
| | | Faulty oil pressure valve | Contact an Official Solé Diesel Service. |
| | | Oil level too high. | Reset oil level. |
| | | Obstruction of oil lines. | Contact an Official Solé Diesel Service. |
| HIGH FUEL CONSUMPTION | GENERAL | Low compression pressure. | Check compression. |
| | | Electrical overload. | Reduce electrical load. |
| | | The regulator is not working properly. | Contact an Official Solé Diesel Service. |
| | FUEL SYSTEM | Fuel injection timing malfunction. | Adjust fuel injection timing |
| | INLET AND EXHAUST SYSTEM | Clogged air filter | Replace the air filter element. |
| LOW POWER | GENERAL | Incorrect valve clearance. | Perform valve adjustment. |
| | FUEL SYSTEM | Clogged fuel filter. | Replace fuel filter. |
| | | Dirty or faulty fuel injectors. | Clean, test and/or replace fuel injector which is not operating properly. |
| | | Water in fuel system. | Clean fuel system with proper products. Inspect the source of the water inlet. |
| | | Fuel injection timing malfunction. | Adjust fuel injection timing |
| | INLET AND EXHAUST SYSTEM | Clogged air filter | Replace the air filter element. |
| Exhaust detonations | | Inspect exhaust system. Replace exhaust system components that are not operational. | |
| ENGINE OVERHEATING | GENERAL | Low compression pressure. | Check compression. |
| | | Electrical overload. | Reduce electrical load. |
| | LUBRICATION SYSTEM | Faulty oil pump. | Contact an Official Solé Diesel Service. |
| | | Oil viscosity too high. | Check oil specifications according to Technical Specifications. |
| | | Oil level too low. | Reset oil level. Inspect the marine generator set for leaks. |

Troubleshooting



| GENSET FAILURE | SYSTEM | PROBABLE CAUSES | RECOMMENDED ACTIONS |
|-----------------------------------|---------------------------------|---|---|
| ENGINE OVERHEATING | COOLING SYSTEM | Faulty coolant water pump. | Check coolant pump (impeller, pump sealing). |
| | | Plugged or restricted-pitch salt water tap. | Clean the tap, check if the salt water pump impeller is damaged. |
| | | Faulty salt water pump. | Check sea water pump (impeller, pump sealing). |
| | | Clogged water cooler. | Clean the water cooler. |
| | | Low coolant level. | Restore normal coolant level for operation. |
| | Thermostat is not operational. | Replace the thermostat. | |
| | INLET AND EXHAUST SYSTEM | Clogged air filter | Replace the air filter element. |
| GENERATOR SET WITH NOISE | GENERAL | Low compression pressure. | Check compression. |
| | | Electrical overload. | Reduce electrical load. |
| | | Exhaust system leakage. | Inspect exhaust system. Replace exhaust system components that are not operational. |
| | | Excessive vibration. | Check engine brackets. Inspect engine and retighten loose parts. |
| | Incorrect valve clearance. | Perform valve adjustment. | |
| | ALTERNATOR (AC) | AC worn alternator bearing. | Replace the CA alternator bearing. |
| | | Faulty AVR regulator plate. | Replace AVR regulator plate. |
| FAULTY BATTERY CHARGE | ELECTRICAL SYSTEM (DC) | Discharged or empty battery. | Charge the battery or replace it with a new one. |
| | | Loose or corroded battery connections. | Check the battery connections are correct, clean and tight. |
| | | Faulty DC alternator regulator. | Replace alternator. |
| | | DC alternator belt tension. | Check belt tension and change if necessary. |
| LOW OR ZERO OUTPUT VOLTAGE | GENERAL | Electrical overload. | Reduce electrical load. |
| | | The regulator is not working properly. | Contact an Official Solé Diesel Service. |

Troubleshooting



| GENSET FAILURE | SYSTEM | PROBABLE CAUSES | RECOMMENDED ACTIONS |
|---|------------------------|--|---|
| LOW OR ZERO OUTPUT VOLTAGE | ALTERNATOR (AC) | CA open output breaker. | Close the CA output breaker. |
| | | Open wiring, terminals or exciter field pin. | Check continuity. |
| | | The main field (rotor) is not operational (open or earthed). | Test and/or replace alternator assembly. |
| | | Stator is not operational (open or earthed). | Test and/or replace alternator assembly. |
| | | Generator set without excitation. | Contact an Official Solé Diesel Service. |
| | | After generator set excitation, it is deactivated | Check if the wiring matches the diagrams in the annex. |
| | | Faulty AVR regulator plate. Blown AVR regulator plate fuse. | Replace AVR regulator plate. Replace AVR regulator plate fuse. |
| VOLTAGE TOO LOW | ALTERNATOR (AC) | Voltage is too low without load. | Calibrate voltage. Check revolutions. Check windings. |
| VOLTAGE TOO HIGH | ALTERNATOR (AC) | Voltage is too high without load. | Calibrate voltage. Replace AVR regulator plate. |
| LOW LOAD VOLTAGE BELOW THE NOMINAL VALUE | ALTERNATOR (AC) | Low load voltage below the nominal value. | Calibrate voltage. Too high current, too low $\cos \phi$, speed 4 % below nominal value. Replace AVR regulator plate. Check diodes and release wires. |
| LOW LOAD VOLTAGE ABOVE NOMINAL VALUE | ALTERNATOR (AC) | Low load voltage above the nominal value. | Calibrate voltage. Replace AVR regulator plate. |
| UNSTABLE VOLTAGE | ALTERNATOR (AC) | Unstable voltage. | Check the engine rotational speed is uniform. Check the stability of the regulator by adjusting the potentiometer. |



Section 7 – Technical specifications

Single-Phase

General data

| | | | |
|------------------------|----------------|-------------------------------------|---------|
| Maximum power*: | 59 kW (60 kVA) | Dimensions and weights: | 230 V |
| Prime Power**: | 53,6 kW | Total length without canopy: | 256,5 A |
| Frequency: | 50 Hz | Total width without canopy: | 1 |

Dimensions and weights

| | | | |
|-------------------------------------|---------|----------------------------------|---------|
| Total length without canopy: | 1760 mm | Total length with canopy: | 2150 mm |
| Total width without canopy: | 899 mm | Total width with canopy: | 865 mm |
| Total height without canopy: | 969 mm | Total height with canopy: | 1048 mm |
| Dry weight without canopy: | 996 Kg | Dry weight with canopy: | 1108 Kg |

Engine

| | | | |
|----------------------------------|----------------------------|------------------------------|----------------------------|
| Base engine manufacturer: | Deutz | Diameter: | 108 mm (4,25 in) |
| Model Solé Diesel: | SDZ-109E | Stroke: | 130 mm (5,12 in) |
| Type: | 4 stroke | Compression ratio: | 19:1 |
| Engine RPM: | 1500 | Injection system: | Mechanical and direct |
| Number of cylinders: | 4 | Intake system: | Turbocharged |
| Total displacement: | 4764 cc | SAE Flywheel housing: | SAE 2 |
| Oil: | SAE 15W40 | Coolant capacity: | 17,5 L (4,62 gal) |
| Oil capacity: | 11 L (2,91 gal) | Flywheel: | SAE 11 1/2 |
| Power: | 81 kW (110,16 CV) | Coolant flow rate: | 141,45 l/min (37,37 gal/m) |
| Salt water flow rate: | 107,43 l/min (28,38 gal/m) | Intake air flow rate: | 5,5 m ³ /m |
| Starting aid: | Supercharger | | |

Fuel system details

| | | | |
|------------------------------|-----------------------|-----------------------------|---------------------|
| Consumption: | 4,8 L/H (1,27 Gal/H) | Fuel type: | Diesel |
| Consumption at 50 %: | 8,9 L/H (2,35 Gal/H) | Fuel standards: | Fueloil diesel ASTM |
| Consumption at 75 %: | 13 L/H (3,43 Gal/H) | Injection pump type: | Individual |
| Consumption at 100 %: | 17,3 L/H (4,57 Gal/H) | Governor type: | Electronical |

Electrical system

| | | | |
|-------------------------------|--------------------|------------------------------|------|
| Battery voltage: | 24 V | Stop solenoid type: | ETS |
| Starter motor: | 4 kW | Alternator: | 35 A |
| Battery cable section: | 50 mm ² | Battery cable length: | 5 m |

Installation details

| | | | |
|--|-----------------|---------------------------------------|-----------------|
| Exhaust hose inner diameter: | 90 mm (3,54 in) | Maximum fuel lift height: | 1,3 m (4,27 ft) |
| Sea water hose inner diameter: | 42 mm (1,65 in) | Maximum raw water lift height: | 4 m (157,48 in) |
| Fuel feeding hose inner diameter: | 12 mm (0,47 in) | Maximum sea water temperature: | 32 S/N (32 S/N) |
| Fuel return hose inner diameter: | 12 mm (0,47 in) | Maximum installation angle***: | 10 ° |
| Minimum battery capacity: | 24 V 90 Ah | | |

Alternator details

| | | | |
|-------------------------|--------------|---------------------------------------|------------------------|
| Brand: | Meccalte | Cos φ: | 1 |
| Model: | ECP34 1S 4 C | Tropicalized: | S |
| Regulator type: | DSR | Excitation system: | BRUSHLESS |
| Number of poles: | 4 | Voltage regulation accuracy**: | 0,01 |
| Isolation type*: | H | Standards: | EN60034-1, IEC 60034-1 |
| IP protection*: | 23 | Alternator type: | Synchronous |

Tightening torques



Section 8 – Tightening torques

Important nuts and screws.

| TIGHTENING VALUES | 60 GSC | |
|----------------------------------|----------------|----------------|
| | N·m | kgf·m |
| Cylinder head bolts | 1st Phase 50 | 1st Phase 5 |
| | 2nd Phase 130 | 2nd Phase 13 |
| | Retighten 90° | Retighten 90° |
| Crankshaft pulley bolts | 40 to 50 | 4 to 5 |
| | Retighten 60° | Retighten 60° |
| Main bearing caps | 50 | 5 |
| Connecting rod caps | 30 | 3 |
| Flywheel bolt (30-45 mm) | 20 to 30 | 2 to 3 |
| Flywheel bolt (50-85 mm) | 30 to 40 | 3 to 4 |
| Oil pan drain plug | 50 | 5 |
| Oil pan bolts (steel) | 21 to 23 | 2,1 to 2,3 |
| Oil pan bolts (foundry) | 29 to 31 | 2,9 to 3,1 |
| Oil discharge valve | 40 to 44 | 4 to 4,4 |
| Valve locknut | 22 | 2,2 |
| Injection pipe to injection pump | 1st Phase 5 | 1st Phase 0,5 |
| | 2nd Phase 28,5 | 2nd Phase 2,85 |
| Sensors and switches | 18 to 20 | 1,8 to 2 |
| Starter motor nut (terminal B) | 28 to 30 | 2,8 to 3 |
| Rocker cover | 9 to 10 | 0,9 to 1 |
| Oil pump set bolt | 8 to 9 | 0,8 to 0,9 |
| Oil cooler set bolt | 20 | 2 |

Section 9 – Technical appendices

9.1. Wiring diagrams

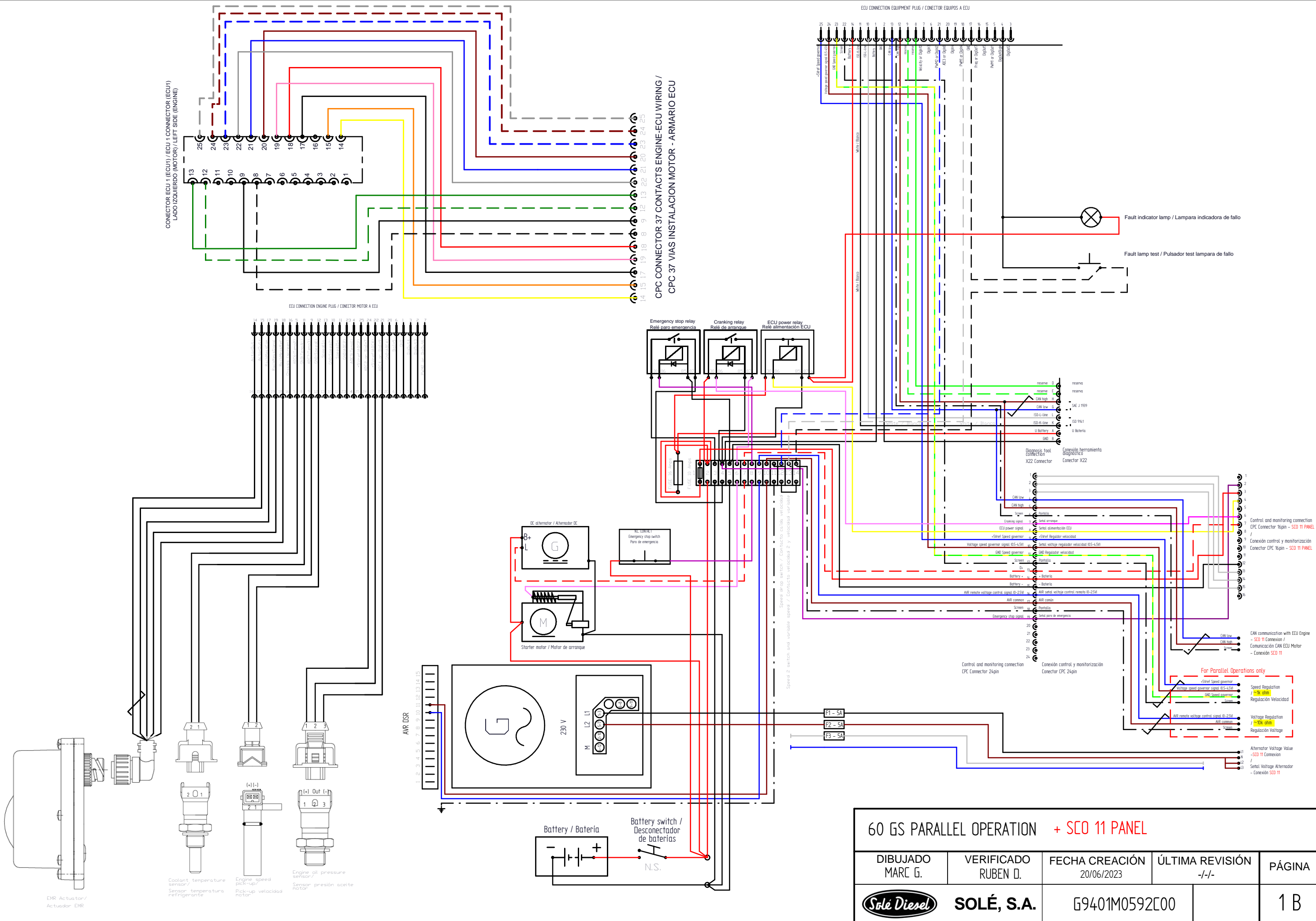

| 60 GS PARALLEL OPERATION + SCO 11 PANEL | | | | |
|---|------------------------|------------------------------|------------------------|--------|
| DIBUJADO MARC G. | VERIFICADO RUBEN D. | FECHA CREACIÓN 20/06/2023 | ÚLTIMA REVISIÓN -/- | PÁGINA |
| | | SOLÉ, S.A. | | 1 B |
| | | G9401M0592C00 | | |

Technical appendices

9.2. Alternator connections

Depending of the genset model, consult the alternator connection:

- Connection Type 1: Alternator MECCALTE 1
- Connection Type 2: Alternator MECCALTE 2
- Connection Type 3: Alternator SINCRO

Connection Type 1:

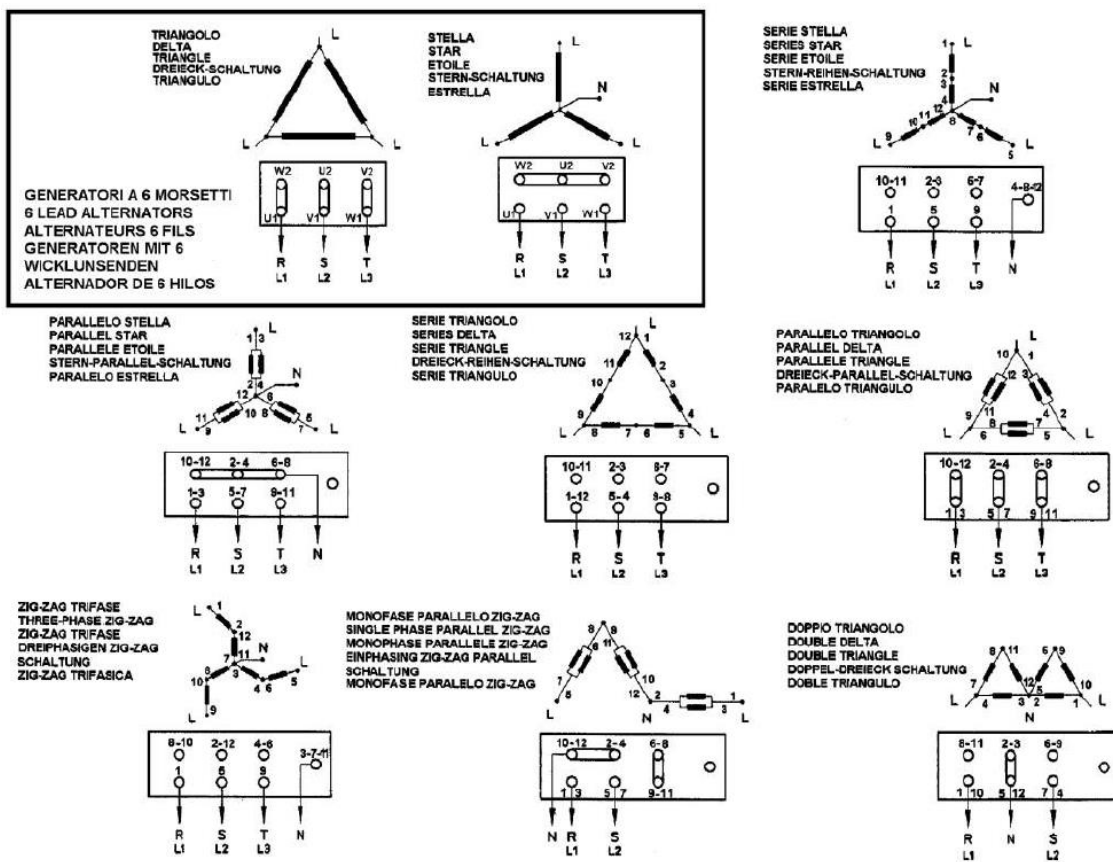

Technical appendices



Connection type 2:

| 12 wires connection | | | | | | | | |
|-----------------------------------|--|--|------|-------|-----------------------|-----|-----|-----|
| Connection | | | | | Winding T0405S3 (***) | | | |
| Series star | | | 50Hz | L - L | 380 | 400 | 415 | 440 |
| | | | 50Hz | L - N | 220 | 230 | 240 | 254 |
| | | | 60Hz | L - L | 460 | 480 | 500 | 530 |
| | | | 60Hz | L - N | 265 | 277 | 290 | 305 |
| Parallel star | | | 50Hz | L - L | 190 | 200 | 208 | 220 |
| | | | 50Hz | L - N | 110 | 115 | 120 | 127 |
| | | | 60Hz | L - L | 230 | 240 | 250 | 265 |
| | | | 60Hz | L - N | 133 | 138 | 145 | 152 |
| Series delta (*) | | | 50Hz | L - L | 220 | 230 | 240 | 254 |
| | | | 50Hz | L - M | 110 | 115 | 120 | 127 |
| | | | 60Hz | L - L | 265 | 277 | 290 | 305 |
| | | | 60Hz | L - M | 133 | 138 | 145 | 152 |
| Parallel delta (*) | | | 50Hz | L - L | 110 | 115 | 120 | 127 |
| | | | 60Hz | L - L | 133 | 138 | 145 | 152 |
| Three phase Zig-Zag (**) | | | 50Hz | L - L | 330 | 346 | 360 | 380 |
| | | | 50Hz | L - N | 190 | 200 | 208 | 220 |
| | | | 60Hz | L - L | 400 | 415 | 430 | 460 |
| | | | 60Hz | L - N | 230 | 240 | 250 | 265 |
| Single phase parallel zig-zag (*) | | | 50Hz | L - L | 220 | 230 | 240 | 254 |
| | | | 50Hz | L - M | 110 | 115 | 120 | 127 |
| | | | 60Hz | L - L | 265 | 277 | 290 | 305 |
| | | | 60Hz | L - M | 133 | 138 | 145 | 152 |
| Single phase double delta (*) | | | 50Hz | L - L | 220 | 230 | 240 | 254 |
| | | | 50Hz | L - M | 110 | 115 | 120 | 127 |
| | | | 60Hz | L - L | 265 | 277 | 290 | 305 |
| | | | 60Hz | L - M | 133 | 138 | 145 | 152 |

Technical appendices



Connection type 3:

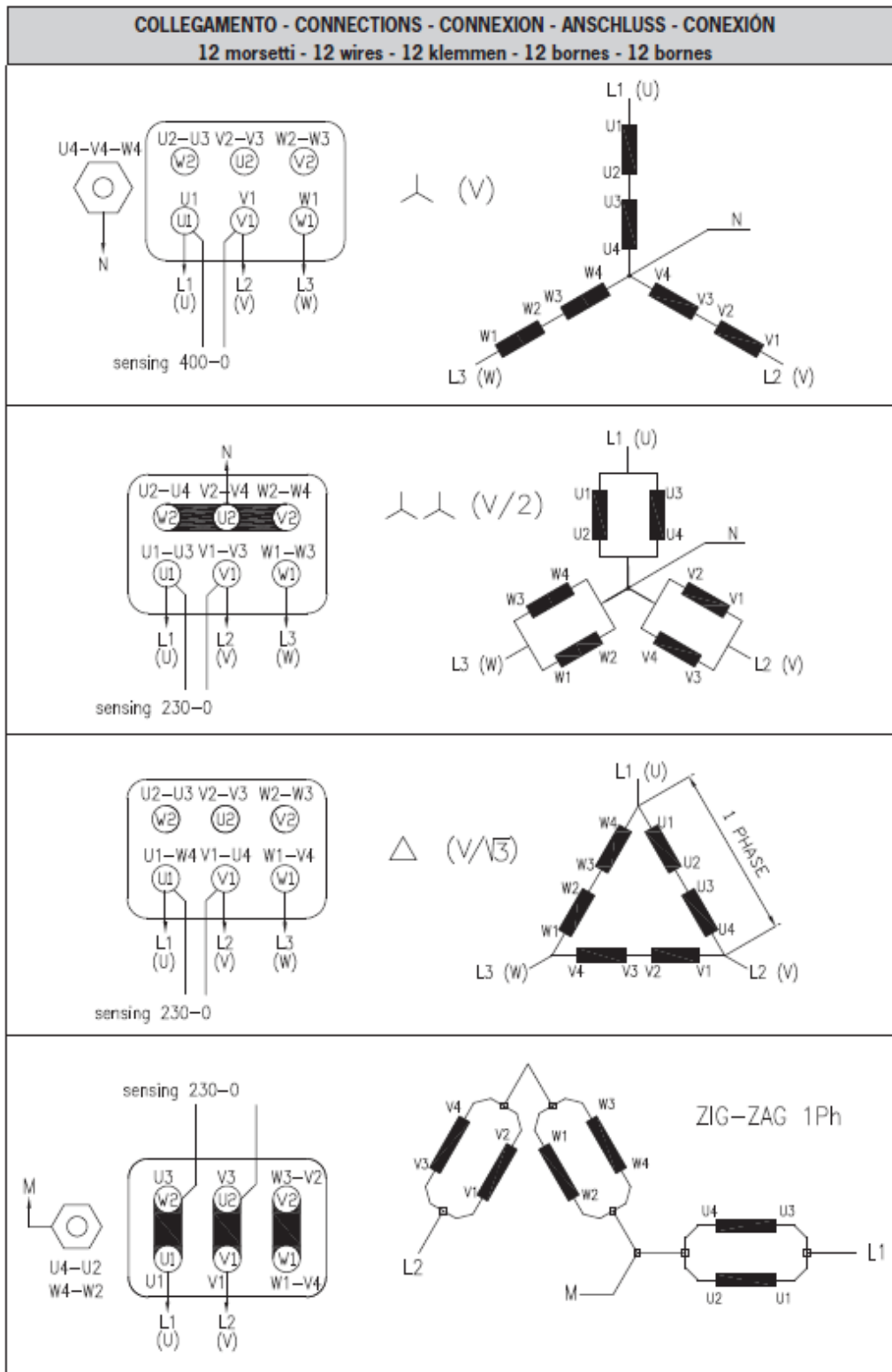

Technical appendices

9.3. Regulator connections

Depending of the genset model, consult the regulator connection:

- Connection Type 1: Alternator MECCALTE 1
- Connection Type 2: Alternator MECCALTE 2
- Connection Type 3: Alternator SINCRO

Connection type 1:

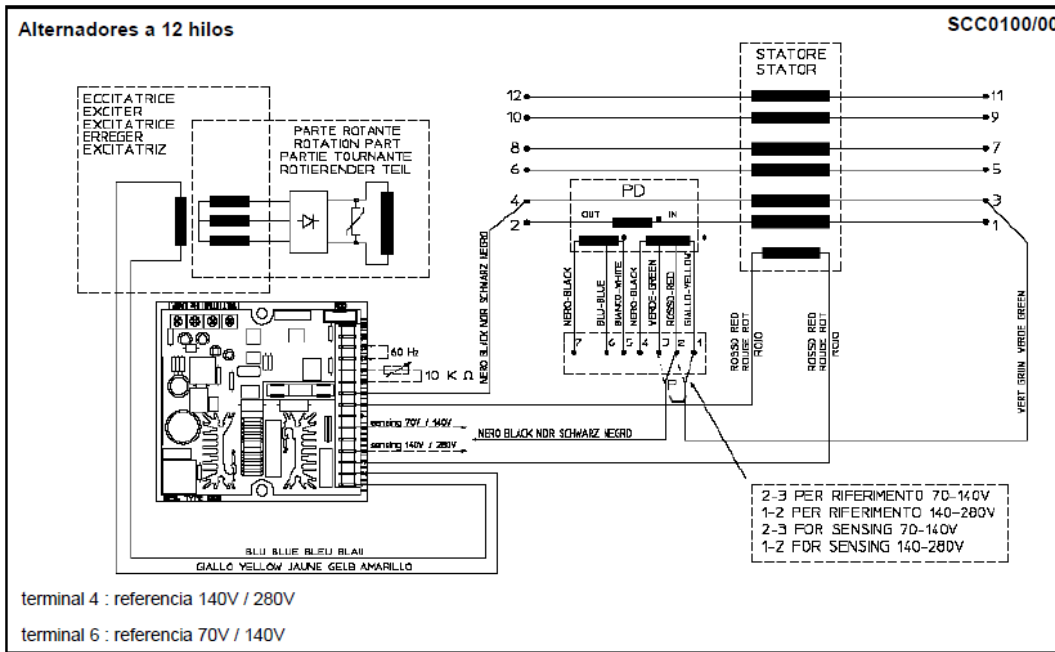

Connection Type 2:

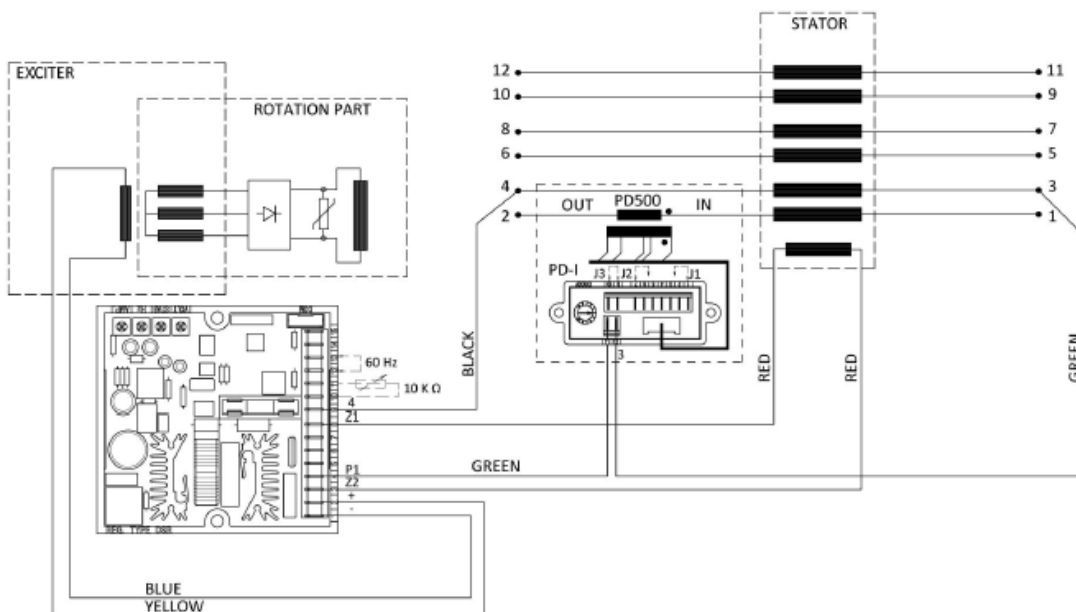

Connection Type 3:

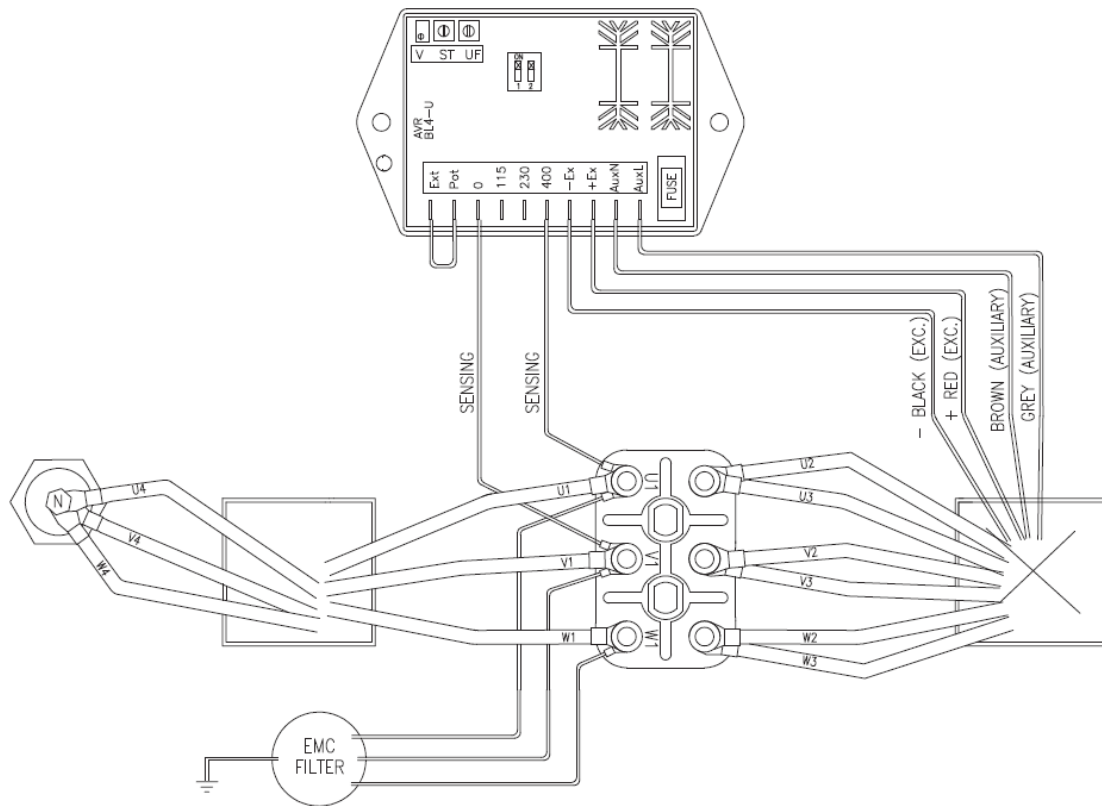

9.4. Overall dimensions

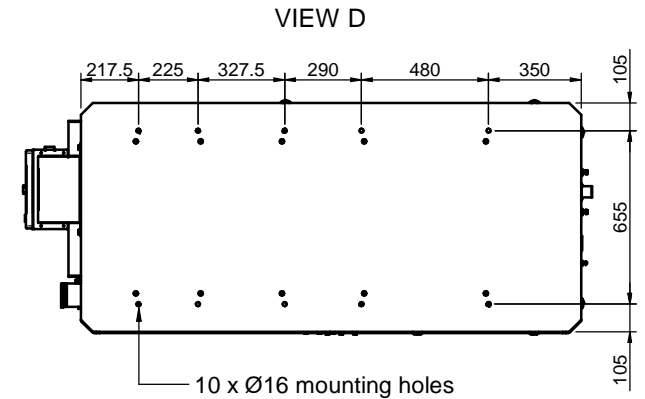
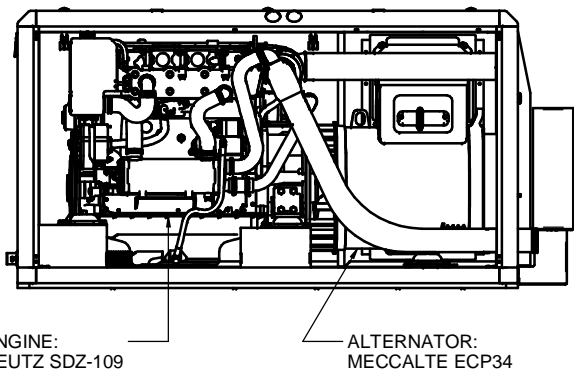
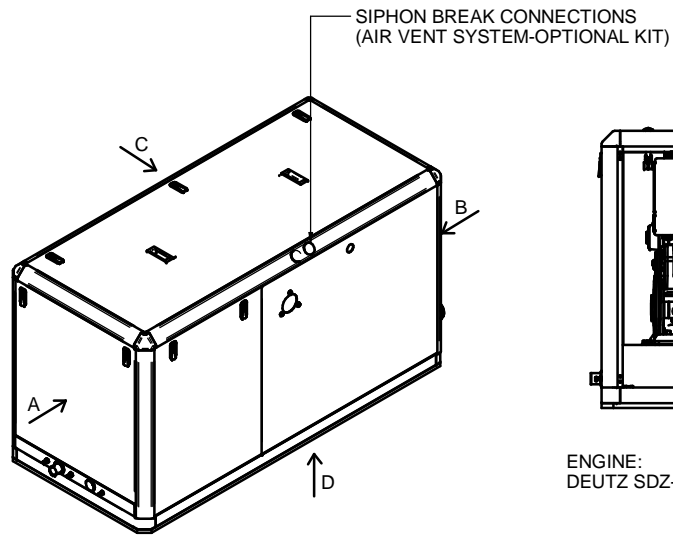

VIEW A

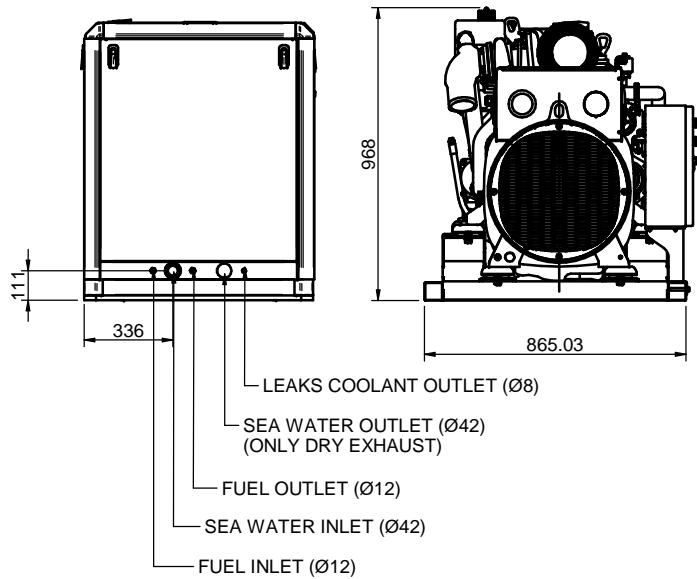

VIEW C

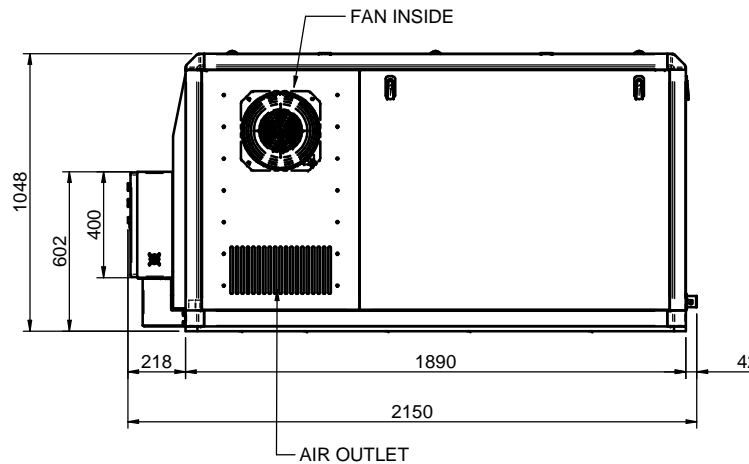

VIEW B

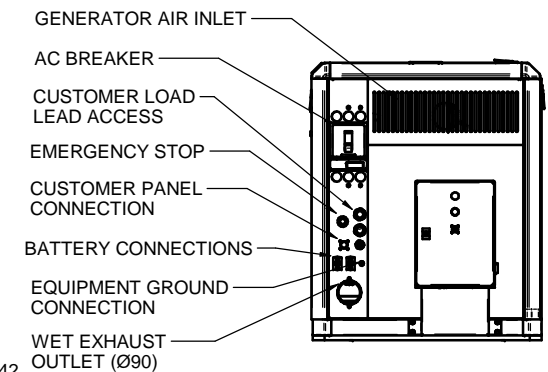

NOTES:

- (1) The control panel (main controller) is supplied without fixing at genset in order to allow their installation on engine room according to installer requirements.
- (2) Dry exhaust available as an option.
- (3) Dimensions in millimeters.

| | | | | | | | |
|-----------------------------|--------|-------|-----------------------------|------------|-------------------|----------------|----------------------|
| Medidas Nominales (mm) | | 100 | GRUPO 60 GSC 24V 230V EMR2 | | | | |
| | a | 300 | GENSET 60 GSC 24V 230V EMR2 | | | | |
| 6 | a | 30 | MATERIAL | ACABADO | TRATAMIENTO | PRESENTACION | ESCALA |
| | | | | | | | -/- |
| 0 | a | 6 | DIBUJADO | VERIFICADO | GRADO PRECISIÓN | FECHA CREACIÓN | ÚLTIMA REVISIÓN |
| | | | OSCARV | P.IGLESIAS | | 19/07/2023 | -- |
| Grado de Precisión DIN-7168 | Fino | ±0.05 | | | SOLÉ, S.A. | | G9401M0592C00 |
| | Medio | ±0.1 | | | | | |
| | Bastio | ±0.2 | | | | | |

Instructions to replace and remove



Section 10 – Instructions to replace and remove

When you decide to replace the genset, please contact Solé Diesel S.A.; will provide relevant instructions regarding the laws in force at the time. When disposing of the whole or parts of this genset, meets LAWS IN FORCE IN THE COUNTRY OF INSTALLATION.

For more information about the materials they are made of the individual components of the generator, contact Solé Diesel S.

Inspection prior to the delivery of generator sets



Section 11 – Inspection prior to the delivery of generator sets

INSPECTION PRIOR TO THE DELIVERY OF GENERATOR SETS

| Installer / Marina information | | | |
|--|-----|--|---|
| Installer Company: | | Installation Date: | |
| Contact Tel. No.: | | E-mail: | |
| Owner's Information | | | |
| Name and surnames: | | | |
| Contact Tel. No.: | | Email: | |
| Generator Set Information | | | |
| Generator set model: | | | |
| Generator set serial number: | | Alternator serial No. (if applicable): | |
| Installation Information | | | |
| Type of electrical installation: | | Total power consumption: kw | |
| Machine chamber operating temperature: | | | °C |
| Angle of the generator set (boat moored): | | | ° |
| Maximum angle of the generator set (navigation conditions) | | | ° |
| Is the wet exhaust elbow above or below the floating line? | | above | below |
| Exhaust, Cooling and Fuel Line Information | | | |
| Int. Diameter of exhaust hose (if applicable): | | mm | Int. Diameter of sea water intake to the pump |
| Int. Diameter of diesel intake: | | mm | |
| Int. Diameter of diesel return intake | | mm | |
| Has an exhaust collector been installed? | YES | Has an air trap been installed? | YES |
| | NO | | NO |
| Verifications Prior to Start-Up | | V/x | Notes |
| Correct engine alignment. | | | |
| Electrical installation connections. | | | |
| Engine oil level | | | |
| Coolant level and concentration. | | | |
| Control panel operation. | | | |
| Transmission belts and belt tension. | | | |
| Airtight water cock | | | |
| Verification of Generator Set No. - Load Operation | | V/x | Notes |
| Oil pressure | | | |
| Bleed the fresh water cooling system. | | | |
| Verify the control panel: normal indications and alarm operation. | | | |
| Water, oil and fuel leaks in the engine. | | | |

Inspection prior to the delivery of generator sets



INSPECTION PRIOR TO THE DELIVERY OF GENERATOR SETS

| Verification of Generator Set Operations with Load | V/x | Notes |
|--|-----|-------|
| Verify the electrical power and voltage of the generator set at full load. | | |
| Engine output and alternator operation at variable load | | |
| Engine temperature and oil pressure. | | |
| Information for the Owner | V/x | Notes |
| Delivery of the instructions manual and generator set-related documents. | | |
| Review of the generator set operator's manual. | | |
| Study the generator set control panel functions. | | |
| Report the first revision date. | | |
| Report the maintenance schedule indicated in the manuals. | | |



Maintenance log

Section 12 - Maintenance log

| DATE | HOURS | DESCRIPTION | SERVICE NAME |
|------|-------|-------------|--------------|
| | | | |
| | | | |
| | | | |
| | | | |
| | | | |
| | | | |
| | | | |
| | | | |
| | | | |
| | | | |
| | | | |
| | | | |
| | | | |
| | | | |
| | | | |
| | | | |
| | | | |
| | | | |
| | | | |
| | | | |
| | | | |
| | | | |
| | | | |
| | | | |
| | | | |
| | | | |



MARINE DIESEL ENGINES · GENSETS · PROPELLERS · ACCESSORIES

C-243 b, km 2 · 08760 Martorell (Barcelona)
Tel. +34 93 775 14 00 · Fax +34 93 775 30 13
www.solédiesel.com · info@solédiesel.com

Follow us:



© Copyright 2019 Solé Diesel. All rights reserved. Texts and specifications are subject to change without notice and without any obligation or liability whatsoever.



U_CTGR60GSC_EN
Revision 0
09/2023