

270PS

S270P

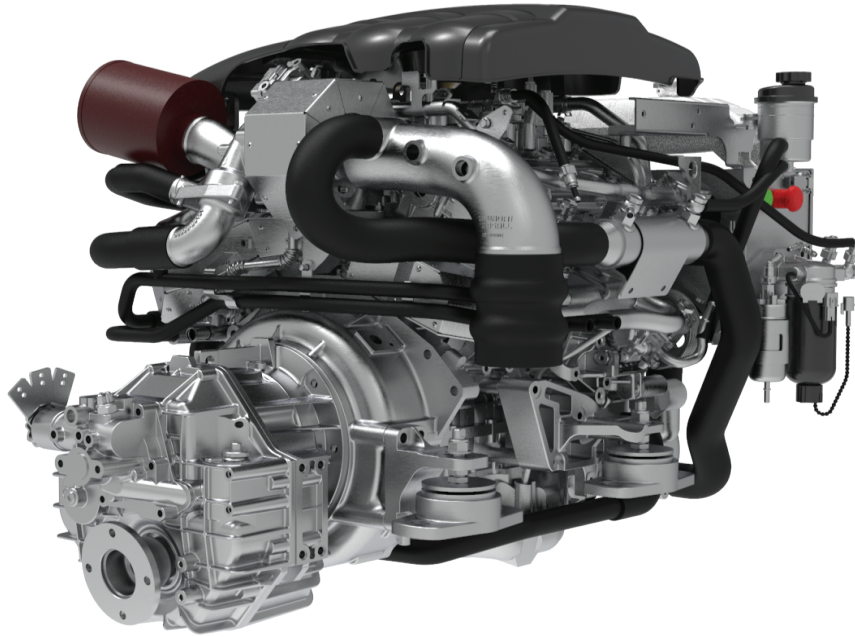

Specifications

Propulsion System	Shaftdrive
Engine Duty Rating	Special Light Commercial (S4)/ Pleasure Duty (S5)
Configuration	4-Stroke, 24-Valve DOHC, E-VGT with Intercooler, Water Cooling
Output [PS (kW)]	270 (199)
Rated RPM	3,800
Cylinders	V6
Displacement [cc]	2,959
Bore X Stroke [mm]	84 X 89
Compression Ratio	17.3 : 1
Max. Torque	57.6 kg·m @ 2,000 rpm
Injection System	Common Rail Direct injection (CRDi) - Piezo Injector
Alternator	12V-150A
Engine Diagnosis	YES
Max Fuel Consump.[l/h]	53.8
Dry Weight [kg]	334
Flywheel	Hyundai Unique
Flywheel Housing	BorgWarner Flange

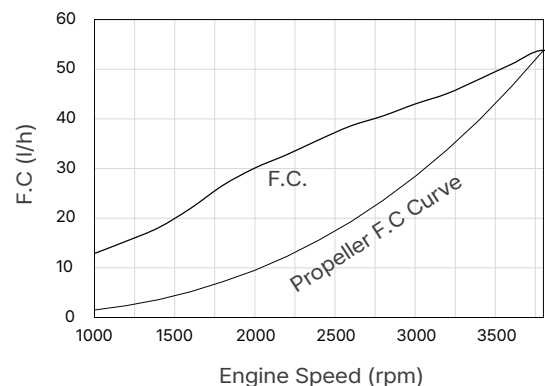
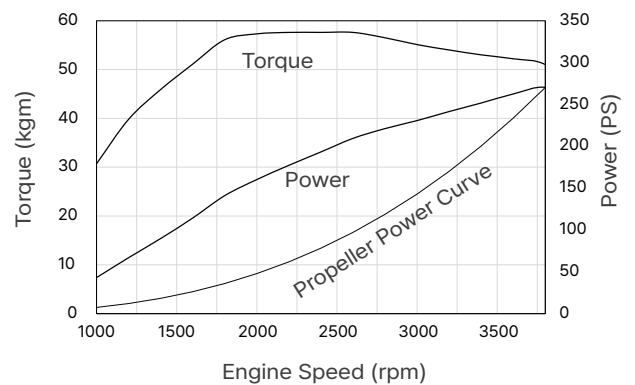

S270P

Technical Descriptions

Engine

- Compacted Graphite Iron (CGI) cylinder block
- Aluminum head
- Nine balance weight crankshaft
- Oil cooled pistons
- V6, 24-valve DOHC
- Hydraulic lash adjusters
- Integrated water jacket
- Low noise duplex timing chain
- Hydraulic timing chain tensioner
- Single serpentine belt system
- Drive belt auto-tensioner

Engine Mounting

- Adjustable engine mounts

Lubrication System

- Easily exchangeable oil filter cartridge
- Electric oil extraction pump
- Seawater cooled transmission oil cooler
- Chain drive engine oil pump

Fuel System

- Common rail direct injection (CRDi)
 - 1,800 bar new generation Piezo injectors
- Fuel filter with sensor detecting water in fuel
- Electric low pressure pump
- Dual pressure control valve
- High pressure fuel pumps

Electrical System

- 12 volt system and 150A alternator
- Auxiliary engine stop button
- Glow plugs for a trouble-free cold start
- NMEA2000 Converter (Optional)
- 2 Pole system (Optional)
- Electronic control system (Optional)

Cooling System

- Seawater pump driven directly from the camshaft
- Seawater cooled intercooler, heat exchanger
- Auxiliary connector for cabin heating
- Corrosion resistant material for seawater circuit

Engine Operating Indicator (EOI)

- Engine self protection and diagnosis
- Displays CAN information
- Displays engine diagnostic error codes
- Audible alarm and control lamps

Air Inlet system

- Oil wetted and reusable air filter
- Crankcase gas vented into the air inlet
- Intake silencer (Optional)

Exhaust System

- Engine coolant cooled exhaust manifold
- Seawater cooled exhaust elbow
- Seawater cooled Hi-Riser (Optional)

Turbocharger

- E-VGT, Electronic Variable Geometry Turbo

Emissions

- IMO NOx Tier II
- EU RCD II
- EPA Tier III
- RINA (Type Approval - Ship)

Dimensions (mm) S270P ZF 68A

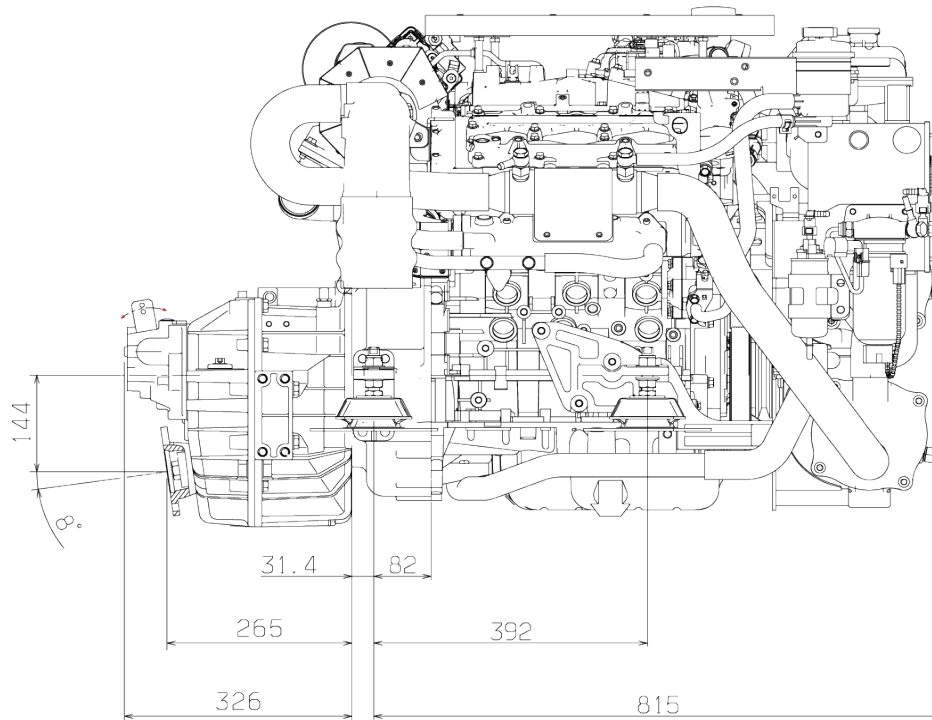

(Homepage) (e-Catalogue)



 **HYUNDAI SEASALL**

124 Jeongoksandan-ro, Seosin-myeon, Hwaseong-si, Gyeonggi-do 18554, Korea

Tel : +82-70-8620-8033 / seasall.info@hyundai-seasall.com