

MARINE TRANSMISSION

DMT190H

■ Standard Scope Of Supply

- Bell Housing (SAE 1, 2)
- Centa Flexible Coupling (14")
- Dual Stage Coupling(11.5")
- Propeller Coupling, Reamer Bolt
- Manual Control Valve
- Oil Cooler
- Cable Bracket

■ Options

- Manual Trolling Valve
- D-trolling Valve
- Electronic Control Valve(12V,24V)
- Manual Trolling Valve + Electronic Control Valve(12V,24V)
- Centa Flexible Coupling (14")
- Mounting Bracket (Flat type, L type)

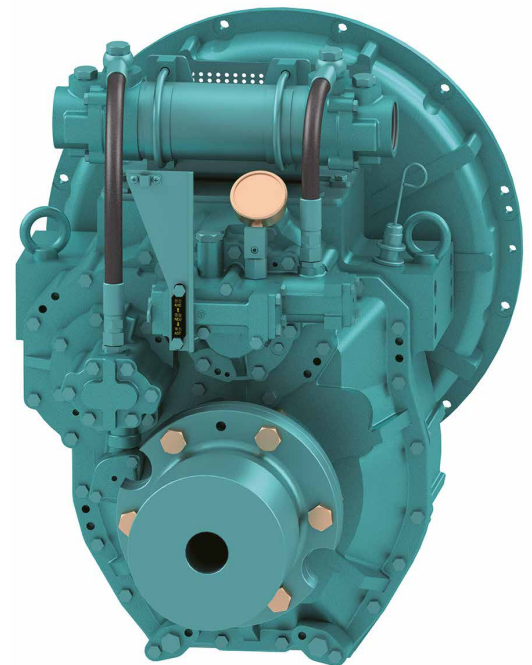

Model	Ratio	Max Input Torque		Capacity/RPM		Capacity/1800RPM		Max Input (RPM)	Bell Housing (SAE)	DRY WEIGHT (kg)
		(kgf.m)	(N.m)	kW	HP	kW	HP			
DMT190H	1.83*, 2.09, 2.51, 3.08, 3.43	180	1765	0.184	0.247	332	446	2500	1, 2	278

*Special Order Ratio

※ The dry weight is the weight that excludes bell housing, coupling (rubber block, dual stage, Centa flexible) and propeller coupling from the standard scope of supply.

※ The capacity for classification may differ from the capacity on the table, please contact our sales team.

DMT190H Dimensions

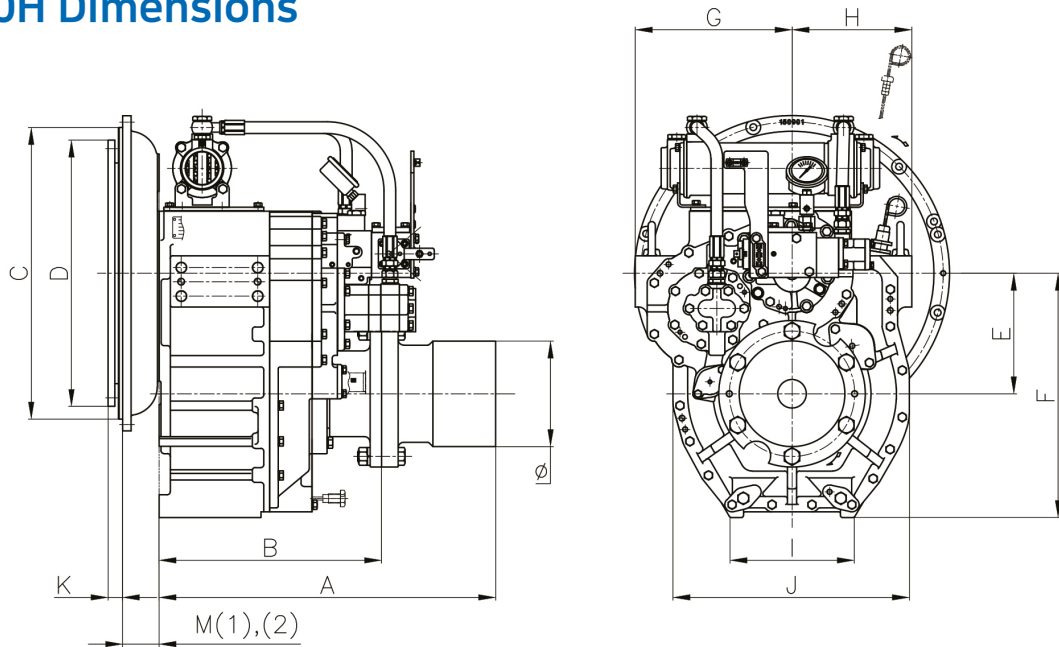

A	B	E	F	G	H	I	J	Ø
518	378	211	428	275	210	218	415	150

Bell Housing Standard	Driving Ring	C	D	M(1)	M(2)	K
SAE#1	14"	511	466	64	88	25
SAE#2	11.5"	447	325	-	-	39

※ M(1) : Standard Coupling Dimension, M(2) : High Flexible Coupling Dimension

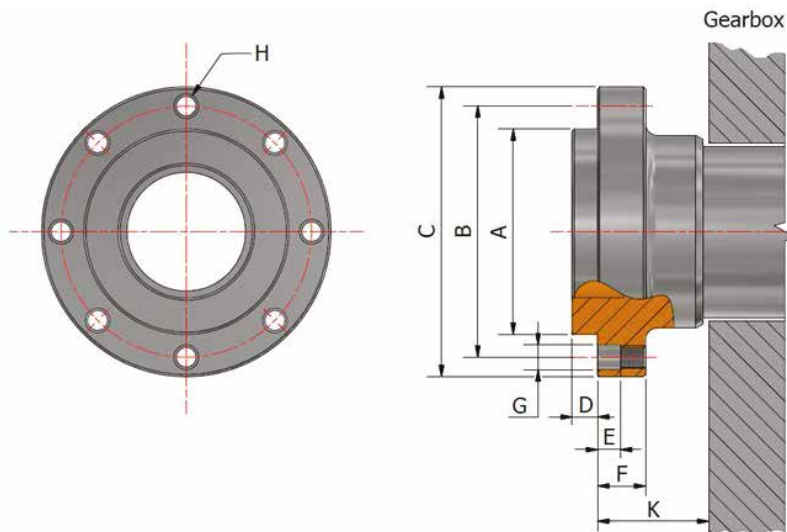

A	B	C	D	E	F	G	H	K
Ø90	$\begin{matrix} 0 \\ -0.02 \end{matrix}$	Ø110	Ø127	11.5	10	21	8-M10 P1.25	37.5