

MARINE GENERATORS

36 GS/GSC ELECTRONIC GOV.

Single-Phase

General data

Maximum power*	36 kW (36 kVA)	Voltage	230 V
Prime Power**	32.7 kW	Amperage	156 A
Frequency	50 Hz	Phases	1

Dimensions and weights

Total length without canopy	1428 mm	Total length with canopy	1605 mm
Total width without canopy	740 mm	Total width with canopy	740 mm
Total height without canopy	785 mm	Total height with canopy	841 mm
Dry weight without canopy	560 Kg	Dry weight with canopy	598 Kg

Engine

Base engine manufacturer	Mitsubishi	Diameter	94 mm (3.7 in)
Model	SM-56	Stroke	120 mm (4.72 in)
Type	Diesel, 4 stroke	Compression ratio	17:1
Engine RPM	1500	Injection system	Mechanical and direct
Number of cylinders	4	Intake system	Turbocharged
Total displacement	3331 cc	SAE Flywheel housing	SAE 3
Oil	SAE 15W40	Coolant capacity	13 L (3.43 gal)
Oil capacity	10 L (2.64 gal)	Flywheel	SAE 11 1/2
Power	40.5 kW (55.08 CV)	Coolant flow rate	105 l/min (27.74 gal/m)
Salt water flow rate	38 l/min (10.04 gal/m)	Intake air flow rate	2.9 m3/m
Exhaust type	Wet exhaust elbow	V-Belt Protection	Optional

Rating conditions according to ISO 3046 (100 kPa barometric pressure, 30 % relative humidity abd 25 °C (77 ° F))

* Maximum output power: maximum power supplied by the genset at full load

** Prime Power: rated power according to ISO 3046 and ISO 8528-1. 10 % overload capacity one hour in twelve hours.

Fuel system details

1 kW 1,36 CV 1 kW 1,36 HP (metric) 1 kW 1,36 CH

45722 - 3/25

Fuel system details

Consumption 25%	3.2 l/h (0.85 gal)	Fuel type	Diesel
Consumption 50%	5.2 l/h (1.37 gal)	Fuel standards	Fueloil diesel ASTM
Consumption 75%	7.4 l/h (1.95 gal)	Injection pump type	In line
Consumption 100%	9.7 l/h (2.56 gal)	Governor type	Mechanical

Electrical system

Battery voltage	12 V	Stop solenoid type	ETR
Starter motor	2.2 kW	Alternator	50 A
Earth isolated	Included	IP 65 box kit	Optional
SCO 11 double panel	Optional	Current transformers	Included

Installation details

Exhaust hose inner diameter	75 mm (2.95 in)	Maximum fuel lift height	0.3 m (0.98 ft)
Sea water hose inner diameter	32 mm (1.26 in)	Maximum raw water lift height	2.5 m (98.43 in)
Fuel feeding hose inner diameter	8 mm (0.31 in)	Maximum sea water temperature	32 ° (89.6 °F)
Fuel return hose inner diameter	8 mm (0.31 in)	Maximum installation angle***	15 °
Minimum battery capacity	12 V 95 Ah		

Alternator details

Brand	Meccalte	Cos Phi	1
Model	ECP32 1M 4 C	Tropicalized	Yes
Regulator type	DSR	Excitation system	Brushless
Number of poles	4	Voltage regulation accuracy**	0.01
Isolation type*	H	Alternator type	Synchronous
IP protection	23	Standards	EN60034-1, IEC 60034-1

Standard equipment

Wire earth isolated	SCO11 Control Panel
Silent Blocks	Electronic governor wiring 6 m
Oil extraction pump	User manual
Electronic governor	Packing

Optional accessories

Siphon break kit mandatory if generator is below waterline	Wet Exhaust System
Engine electrical system at 24 V	Water Filters
Service/Cruise Kits: fuel and oil filters, raw water pump, impeller, alternator belt,...	Sea water cock
Dry Exhaust system	Welcome Kit

* Other protections available

** With load from 0 to 100%, speed variation from -2% up to +5%, power factor 0,8 linear and balanced load.

*** In all directions

For other requirements please contact the Sales Dept.

SCO 11 Panel



General Description

Graphic LCD with light, 128 x 64 pixels display
Genset measures (see Display Information)
Configuration protected by user and password
Running hour indication
Multilengüaje
Event history log
Genset protections (see Alarm Management)
Preheating function
D+ pre-excitation Terminal
Built-in PLC function
CAN bus information with SAE J1939 protocol
Maintenance hours control
Dimensions 195 x 135 x 47 mm
Board Cutting 172 x 112 mm
Weight 450 g

Alarm Management

Shut Downs (SD)
High coolant temperature
Low oil pressure
Overspeed
Overload*
Short circuit*
Overcurrent*
Over/Under voltage
Over/Under frequency
Emergency stop
Warnings (WRN)
High coolant temperature
Low oil pressure
Over/Under Battery voltage
Maintenance request
Sensor failure detection (FLS)

Operating modes

OFF Mode
MAN Mode (manual start/stop engine)

Power Supply

Voltage supply 12/24 DC with fuse protection
Consumption 80mA (12V) or 51 (24V)

Operating Conditions

Operating temperature -20+70 °C
Humidity 95 % without condensation
Front Panel Protection IP65
Standard Conformity
EN 61000-6-2, EN 61000-6-4, EN 61010-1
EN 60068-2-6 (2÷25 Hz / ±1,6 mm; 25÷100 Hz / 4.0 g)
EN 60068-2-30:2005 25/55°C, RH 95%, 48hours
EN 60529 (front panel IP65, back side IP20)

Display Information

Measurement
L1-L3 Voltage (V), Frequency (Hz), Oil Pressure (bar)
Coolant Temperature (°C), Battery voltage (V), RPM
Active Power* (kW), Apparent Power* (kVA), Current* (A), PF*
History log

AUT Mode (auto start/stop engine)

Optional: Parallel Kit Electrical Cabinet



General Description

Control and Power box for parallel operation
COMAP Inteligen200 Panel (See Panel Features)
Current Transformers (See Alternator Measurements)
Power Isolating Switch
Automatic Synchronism
Marine Generator Set Protections (See Alarm Management)
Power and Control Electrical Protection
Communication Control Cable Extensions (See Extensions)
Power inputs and outputs
Automatic or manual control switch
Audible and visual alarm
Can BUS communication with the control unit and the parallel box
Emergency Stop button
IP 65 Protection

Alarm Management

Shut-down (SD)
High engine coolant temperature
Low oil pressure
Over speed
Overload
Short circuit
Battery charge failure
High/low voltage
High/Low Frequency
Emergency stop button
Remote alarms
Warnings (WRN)
High engine coolant temperature
Low oil pressure
High/low battery voltage
Maintenance warning

Optional Equipment

Inteligen200 Remote Double Panel
It allows the same operation and functionality as main Inteligen200
They are connected with an RS485 port

Alternator Measurements

Current transformers
Allows the following readings:
Current (A), Active Power (kW), Apparent Power (kVA) and PF
Earth isolated transformers

Extension

Control wiring. Box-Group (6/12/24 m)
Mitsubishi / Deutz
60974209 / 60994210P - 6 m
60974212 / 60994212P - 12 m
60974213 / 60994213P - 24 m
Wiring for communication between boxes (3/6/12 m)
60994503 - 3 m
60994522 - 6 m
60994521 - 12 m
Remote panel extension (12/24/36 m)
60972104 - 12 m
60972105 - 24 m
60972110 - 36 m

Inteligen200 Panel Features

Group and load Synchronization
Marine generator set measures
L1-L3 Voltage (V), frequency (Hz), Oil pressure (bar)
Coolant temperature (°C), battery voltage (V), RPM
Power* (kW), Apparent Power* (kVA), Current* (A), PF*
Remote panel
2 x 10 A Binary outputs
History log
Running hour indicator
Multilanguage
Configuration protected by password
Integrated PLC
Communication and Extension Module Plug-in
4G/LTE communication standard
GPS

Remote panel extension (12/24/36 m)
Binary and Communication Input/Output Extension Module

Dimensions

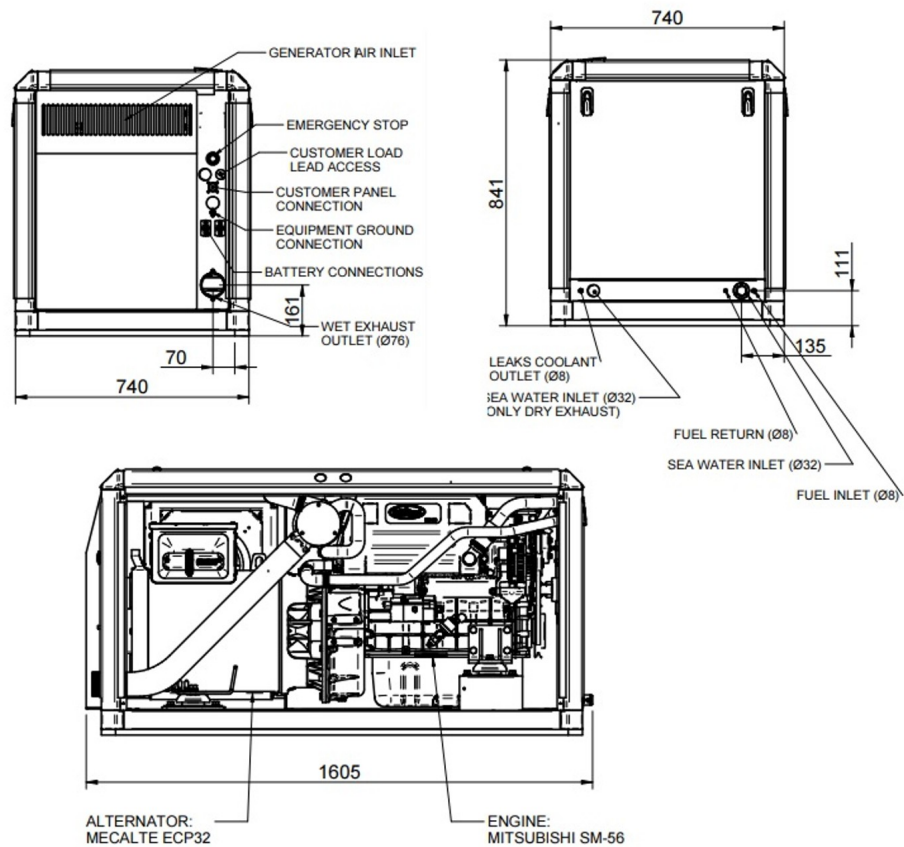
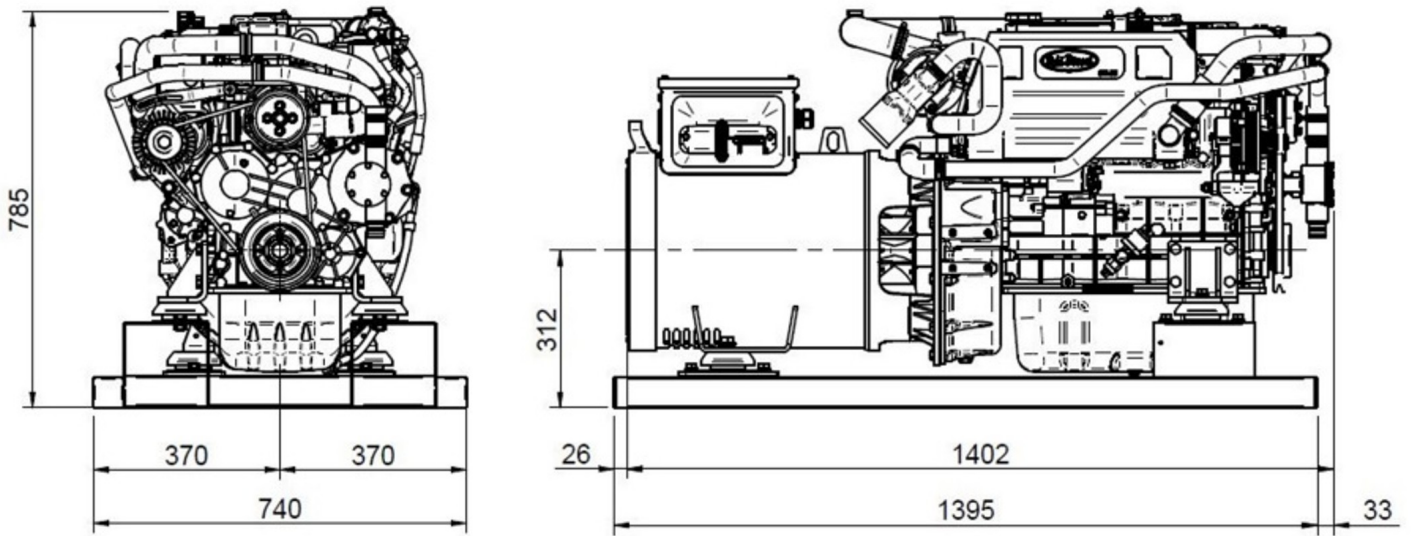

Authorized dealer



Detailed drawings, brochures and manuals are available on the web soleadance.com. All rights reserved. Technical specifications, data and presentation are subjected to variations, changes and updates without prior notice. Non-contractual information.

