

## MARINE GENERATORS

# 36 GS/GSC 230V

Single-Phase

### General data

<b>Maximum power*</b>	36 kW (36 kVA)	<b>Voltage</b>	230 V
<b>Prime Power**</b>	32.7 kW	<b>Amperage</b>	156 A
<b>Frequency</b>	50 Hz	<b>Phases</b>	1

### Dimensions and weights

<b>Total length without canopy</b>	1428 mm	<b>Total length with canopy</b>	1605 mm
<b>Total width without canopy</b>	740 mm	<b>Total width with canopy</b>	740 mm
<b>Total height without canopy</b>	785 mm	<b>Total height with canopy</b>	841 mm
<b>Dry weight without canopy</b>	560 Kg	<b>Dry weight with canopy</b>	598 Kg

### Engine

<b>Base engine manufacturer</b>	Mitsubishi	<b>Diameter</b>	94 mm (3.7 in)
<b>Model</b>	SM-56	<b>Stroke</b>	120 mm (4.72 in)
<b>Type</b>	Diesel, 4 stroke	<b>Compression ratio</b>	17:1
<b>Engine RPM</b>	1500	<b>Injection system</b>	Mechanical and direct
<b>Number of cylinders</b>	4	<b>Intake system</b>	Turbocharged
<b>Total displacement</b>	3331 cc	<b>SAE Flywheel housing</b>	SAE 3
<b>Oil</b>	SAE 15W40	<b>Coolant capacity</b>	13 L (3.43 gal)
<b>Oil capacity</b>	10 L (2.64 gal)	<b>Flywheel</b>	SAE 11 1/2
<b>Power</b>	40.5 kW (55.08 CV)	<b>Coolant flow rate</b>	105 l/min (27.74 gal/m)
<b>Salt water flow rate</b>	38 l/min (10.04 gal/m)	<b>Intake air flow rate</b>	2.9 m3/m
<b>Exhaust type</b>	Wet exhaust elbow	<b>V-Belt Protection</b>	Optional

Rating conditions according to ISO 3046 (100 kPa barometric pressure, 30 % relative humidity abd 25 °C (77 ° F))

\* Maximum output power: maximum power supplied by the genset at full load

\*\* Prime Power: rated power according to ISO 3046 and ISO 8528-1. 10 % overload capacity one hour in twelve hours.

Fuel system details

1 kW 1,36 CV 1 kW 1,36 HP (metric) 1 kW 1,36 CH

45722 - 3/25

## Fuel system details

<b>Consumption 25%</b>	3.2 l/h (0.85 gal)	<b>Fuel type</b>	Diesel
<b>Consumption 50%</b>	5.2 l/h (1.37 gal)	<b>Fuel standards</b>	Fueloil diesel ASTM
<b>Consumption 75%</b>	7.4 l/h (1.95 gal)	<b>Injection pump type</b>	In line
<b>Consumption 100%</b>	9.7 l/h (2.56 gal)	<b>Governor type</b>	Mechanical

## Electrical system

<b>Battery voltage</b>	12 V	<b>Stop solenoid type</b>	ETR
<b>Starter motor</b>	2.2 kW	<b>Alternator</b>	50 A
<b>Earth isolated</b>	Included	<b>IP 65 box kit</b>	Optional
<b>SCO 11 double panel</b>	Optional	<b>Current transformers</b>	Included

## Installation details

<b>Exhaust hose inner diameter</b>	75 mm (2.95 in)	<b>Maximum fuel lift height</b>	0.3 m (0.98 ft)
<b>Sea water hose inner diameter</b>	32 mm (1.26 in)	<b>Maximum raw water lift height</b>	2.5 m (98.43 in)
<b>Fuel feeding hose inner diameter</b>	8 mm (0.31 in)	<b>Maximum sea water temperature</b>	32 ° (89.6 °F)
<b>Fuel return hose inner diameter</b>	8 mm (0.31 in)	<b>Maximum installation angle***</b>	15 °
<b>Minimum battery capacity</b>	12 V 95 Ah		

## Alternator details

<b>Brand</b>	Meccalte	<b>Cos Phi</b>	1
<b>Model</b>	ECP32 1M 4 C	<b>Tropicalized</b>	Yes
<b>Regulator type</b>	DRS	<b>Excitation system</b>	Brushless
<b>Number of poles</b>	4	<b>Voltage regulation accuracy**</b>	0.01
<b>Isolation type*</b>	H	<b>Alternator type</b>	Synchronous
<b>IP protection</b>	23	<b>Standards</b>	EN60034-1, IEC 60034-1

## Standard equipment

Earth isolated	Anti Vibration Mounts
Amperometric transmitter kit	SCO 10 control panel
4 m electrical wiring extension	Owner´s and alternator manual
Oil extraction pump	Packaging
Rigid bed	

## Optional accessories

Siphon break kit mandatory if generator is below waterline	Wet Exhaust System
Engine electrical system at 24 V	Water Filters
Service/Cruise Kits: fuel and oil filters, raw water pump, impeller, alternator belt,...	Sea water cock
Dry Exhaust system	Welcome Kit

\* Other protections available

\*\* With load from 0 to 100%, speed variation from -2% up to +5%, power factor 0,8 linear and balanced load.

\*\*\* In all directions

For other requirements please contact the Sales Dept.

# SCO 11 Panel



## General Description

Graphic LCD with light, 128 x 64 pixels display
Genset measures (see Display Information)
Configuration protected by user and password
Running hour indication
Multilenguaje
Event history log
Genset protections (see Alarm Management)
Preheating function
D+ pre-excitation Terminal
Built-in PLC function
CAN bus information with SAE J1939 protocol
Maintenance hours control
Dimensions 195 x 135 x 47 mm
Board Cutting 172 x 112 mm
Weight 450 g

## Alarm Management

Shut Downs (SD)
High coolant temperature
Low oil pressure
Overspeed
Overload*
Short circuit*
Overcurrent*
Over/Under voltage
Over/Under frequency
Emergency stop
Warnings (WRN)
High coolant temperature
Low oil pressure
Over/Under Battery voltage
Maintenance request
Sensor failure detection (FLS)

## Operating modes

OFF Mode	AUT Mode (auto start/stop engine)
MAN Mode (manual start/stop engine)	

## Power Supply

Voltage supply 12/24 DC with fuse protection
Consumption 80mA (12V) or 51 (24V)

## Operating Conditions

Operating temperature -20+70 °C
Humidity 95 % without condensation
Front Panel Protection IP65
Standard Conformity
EN 61000-6-2, EN 61000-6-4, EN 61010-1
EN 60068-2-6 (2÷25 Hz / ±1,6 mm; 25÷100 Hz / 4.0 g)
EN 60068-2-30:2005 25/55°C, RH 95%, 48hours
EN 60529 (front panel IP65, back side IP20)

## Display Information

Measurement
L1-L3 Voltage (V), Frequency (Hz), Oil Pressure (bar)
Coolant Temperature (°C), Battery voltage (V), RPM
Active Power* (kW), Apparent Power* (kVA), Current* (A), PF*
History log

## Dimensions

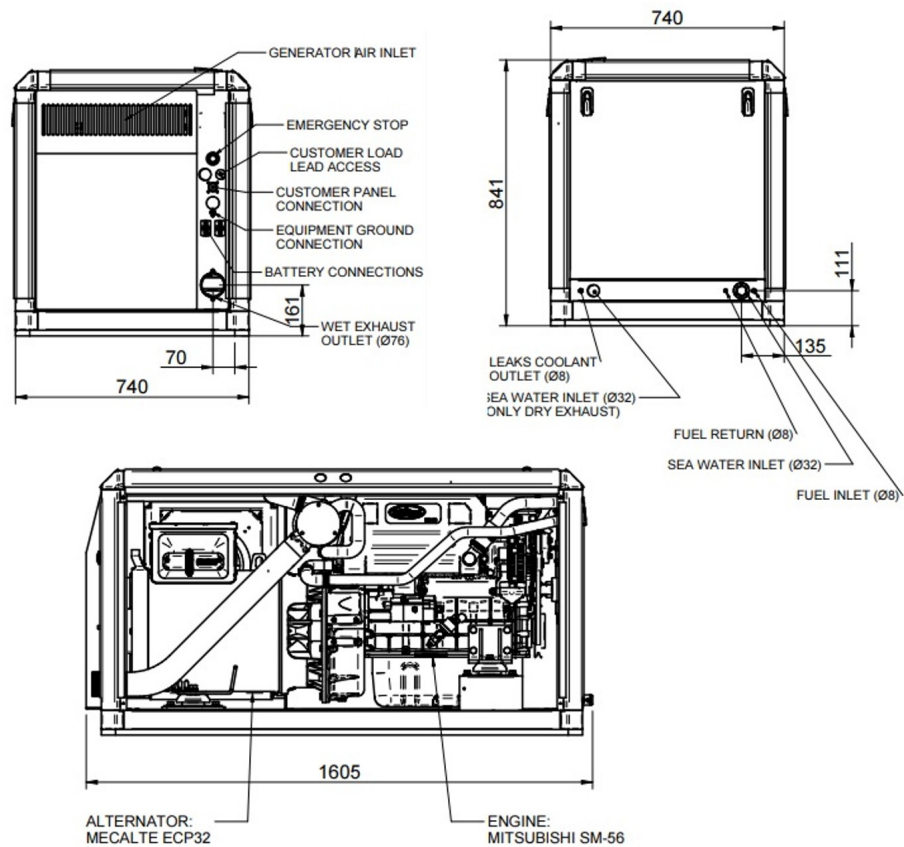
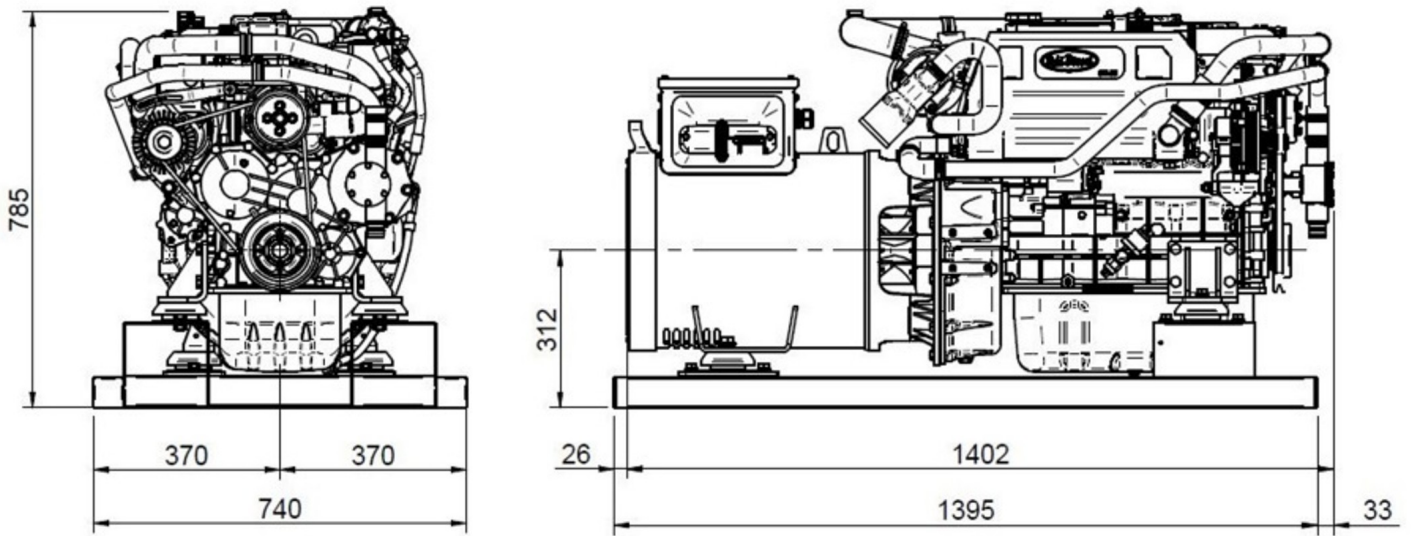

Authorized dealer



Detailed drawings, brochures and manuals are available on the web [soleadance.com](http://soleadance.com). All rights reserved. Technical specifications, data and presentation are subjected to variations, changes and updates without prior notice. Non-contractual information.

