



MARINE GENERATORS

20 GTA/GTAC 240V TAC ELECTRONIC GOVERNOR

Three-Phase

General data

Maximum power*	14.96 kW (18.7 kVA)	Voltage	240 V
Prime Power**	13.6 kW	Amperage	44.99 A
Frequency	60 Hz	Phases	3

Dimensions and weights

Total length without canopy	1036 mm	Total length with canopy	1181 mm
Total width without canopy	580 mm	Total width with canopy	580 mm
Total height without canopy	612 mm	Total height with canopy	668 mm
Dry weight without canopy	282 Kg	Dry weight with canopy	344 Kg

Engine

Base engine manufacturer	Mitsubishi	Diameter	78 mm (3.07 in)
Model	MINI-44	Stroke	92 mm (3.62 in)
Type	Diesel, 4 stroke	Compression ratio	22:1
Engine RPM	1800	Injection system	Mechanical and indirect
Number of cylinders	4	Intake system	Naturally aspirated
Total displacement	1758 cc	SAE Flywheel housing	SAE 5
Oil	SAE 15W40	Coolant capacity	8 L (2.11 gal)
Oil capacity	6 L (1.59 gal)	Flywheel	SAE 7 1/2
Power	17.7 kW (24.07 CV)	Coolant flow rate	100 l/min (26.42 gal/m)
Salt water flow rate	33 l/min (8.72 gal/m)	Intake air flow rate	2.2 m3/m
Exhaust type	Wet exhaust elbow	V-Belt Protection	Included

Rating conditions according to ISO 3046 (100 kPa barometric pressure, 30 % relative humidity and 25 °C (77 ° F))

* Maximum output power: maximum power supplied by the genset at full load

** Prime Power: rated power according to ISO 3046 and ISO 8528-1. 10 % overload capacity one hour in twelve hours.

Fuel system details

1 kW □ 1,36 CV 1 kW □ 1,36 HP (metric) 1 kW □ 1,36 CH

45611 - 11/24

Fuel system details

Consumption 25%	2.1 l/h (0.55 gal)	Fuel type	Diesel
Consumption 50%	2.9 l/h (0.77 gal)	Fuel standards	Fueloil diesel ASTM
Consumption 75%	4 l/h (1.06 gal)	Injection pump type	In line
Consumption 100%	5.3 l/h (1.4 gal)	Governor type	Mechanical

Electrical system

Battery voltage	12 V	Stop solenoid type	ETR
Starter motor	1.7 kW	Alternator	120 A
Earth isolated	Included	IP 65 box kit	Optional
SCO 11 double panel	Optional	Current transformers	Optional

Installation details

Exhaust hose inner diameter	50 mm (1.97 in)	Maximum fuel lift height	0.3 m (0.98 ft)
Sea water hose inner diameter	20 mm (0.79 in)	Maximum raw water lift height	3 m (118.11 in)
Fuel feeding hose inner diameter	G3/8	Maximum sea water temperature	32 ° (89.6 °F)
Fuel return hose inner diameter	1/4 BSPT	Maximum installation angle***	15 °
Minimum battery capacity	12 V 80 Ah		

Alternator details

Brand	Sincro	Cos Phi	0,8
Model	SK 160 MB	Tropicalized	Yes
Regulator type	BL4	Excitation system	Brushless
Number of poles	4	Voltage regulation accuracy**	1%
Isolation type*	H	Alternator type	Synchronous
IP protection	23	Standards	EN 60034-1, IEC 60034-1, ISO 8528-3

Standard equipment

Earth isolated	V-Belt Protection
Double wall injection pipes and fuel leak alarm	Spray stop kit
Dual fuel filter	Sensors certified by the rating company
CO-40 panel for engine/primer mover	Reinforced bed and silentblocks
Electronic regulator	6 m wiring extension
Electronic actuator	Packaging
Documentation: manual, test, declaration of conformity	Oil extraction pump

Optional accessories

Siphon break kit mandatory if generator is below waterline	Exhaust System
Engine electrical system at 24 V	Keel Cooling conversion for dry and wet exhaust
Service/Cruise Kits: fuel and oil filters, raw water pump, impeller, alternator belt,...	Exhaust Hose
Dry Exhaust system	Water Filters

* Other protections available

** With load from 0 to 100%, speed variation from -2% up to +5%, power factor 0,8 linear and balanced load.

*** In all directions

For other requirements please contact the Sales Dept.

COMAP PANEL CO 40



General Description

Control, monitoring and protection for marine engines
(signal alternator not included)
For Emergency, Auxiliary, Harbor and Propulsion engines
Redundant module ID-RPU with hardwired safety
functions activated in backup mode
Switching between primary and secondary battery
(with ID-RPU module)
Connection to engine via primary J1939 and backup J1587 buses
Event driven History record
14 binary inputs, 14 binary outputs, 8 analog inputs
Slave panels for remote control
Type approval from major certification societies
Configuration protected by password
Running hour indication
Multilanguage
D+ pre-excitation Terminal

Alarm Management

1 Emergency stop input
5 Shutdown inputs
1 RPM input
Common warning and common shutdown output terminals
Stop solenoid, fuel solenoid outputs
Redundant power supply
I/O broken wire detection

Optional Equipment

Power supply: Nominal power supply 24 VDC

Power supply range 6 - 36 VDC

Current consumption (depends on supply voltage)

0,34 A at 8 VDC 0,12 A at 24 VDC 0,09 A at 36 VDC

Battery voltage measurement tolerance 2% at 24 V

RTC battery life-cycle 10 year

Operating temperature -10 to +70 °C

Storage temperature -30 to +80 °C

Humidity 95% Without condensation

Alternator Measurements

180 x 120 mm front panel mounted case

Weight 800g

Graphic black-lit LCD display 128x64 pixel resolution with icons
and bar graphs

LED status indicators / Lamp test

Protection front panel IP65

Extension

Oil Pressure (bar)

Oil Temperature (°C)

Coolant Temperature (°C)

Coolant Pressure (bar)

Battery Voltage (V)

RPM

History log

Intelligen200 Panel Features

High coolant temperature

High oil temperature

Fuel leakages

Low oil pressure

Low coolant pressure

Overspeed

Emergency stop

Low battery voltage

Maintenance request

Sensor Fails (FLS)

Flash memory data retention time 10 years

Standard Conformity

Low Voltage Directive

EN 61010-1:95 +A1:97

Electromagnetic Compatibility

EN 61000-6-2, October 2001

EN 61000-6-4, October 2001

IEC 60533, Ed. 2; 1999-11

Dimensions

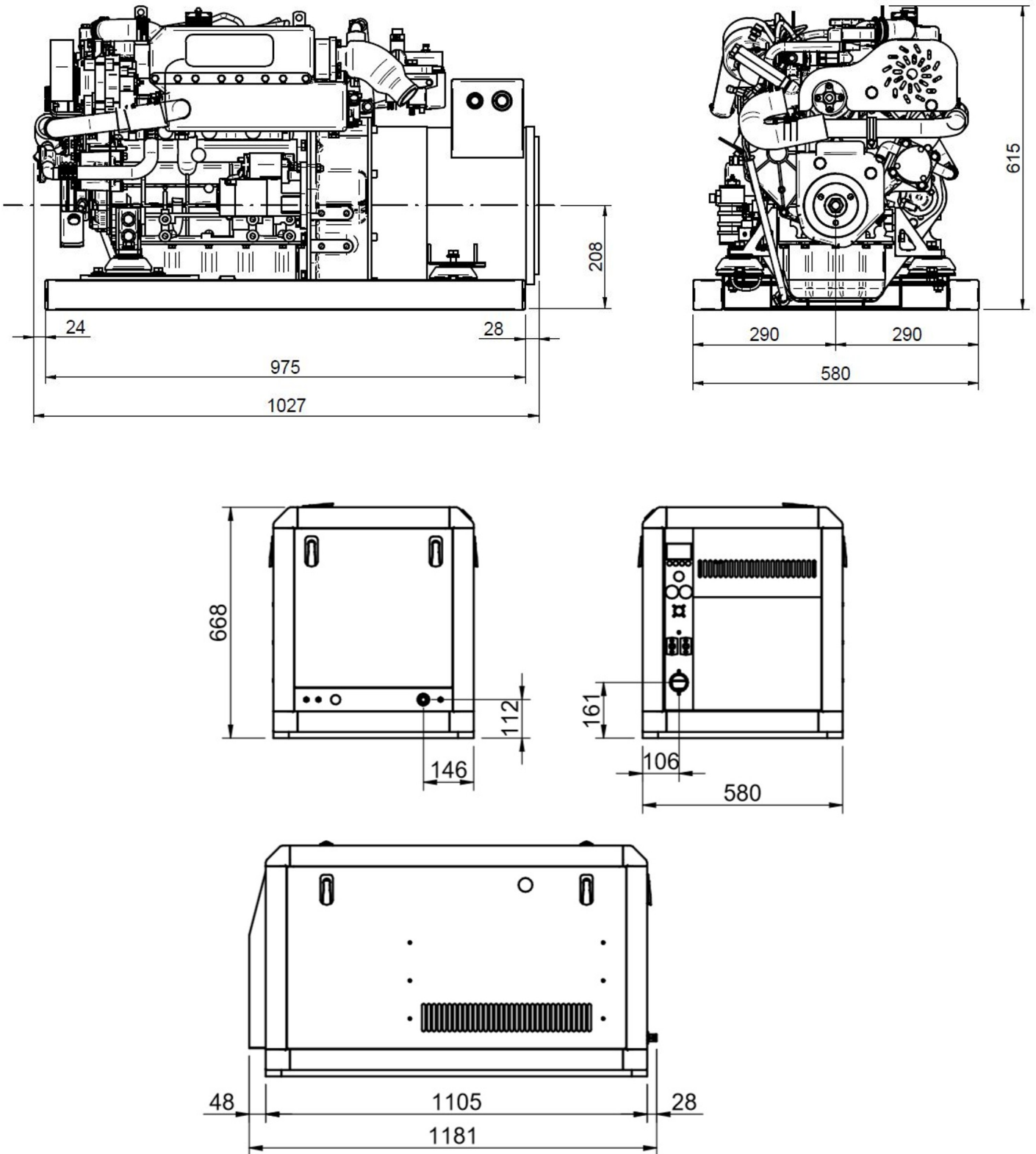

Authorized dealer



Detailed drawings, brochures and manuals are available on the web soleadvantage.com. All rights reserved. Technical specifications, data and presentation are subjected to variations, changes and updates without prior notice. Non-contractual information.

