

10 GS/GSC 230 V TAC

Single-Phase

**General data**

Maximum power*:	8,25 kW (8,25 kVA)	Voltage:	230 V
Prime Power**:	7,5 kW	Amperage:	35,87 A
Frequency:	50 Hz	Phases:	1

Dimensions and weights

Total length without canopy:	885 mm	Total length with canopy:	1032 mm
Total width without canopy:	580 mm	Total width with canopy:	580 mm
Total height without canopy:	609 mm	Total height with canopy:	668 mm
Dry weight without canopy:	271 Kg	Dry weight with canopy:	308 Kg

Engine

Base engine manufacturer:	Mitsubishi	Diameter:	78 mm (3,07 in)
Model Solé Diesel:	MINI-33	Stroke:	92 mm (3,62 in)
Type:	4 No. of Strokes	Compression ratio:	22:1
Engine RPM:	1500	Injection system:	Electronical common rail and direct
Number of cylinders:	3	Intake system:	Naturally aspirated
Total displacement:	1318 cc	SAE Flywheel housing:	SAE 5
Oil:	SAE 15W40	Coolant capacity:	5,7 L (1,51 gal)
Oil capacity:	4 L (1,06 gal)	Flywheel:	SAE 7 1/2
Power:	10 kW (13,6 CV)	Coolant flow rate:	40 l/min (10,57 gal/m)
Salt water flow rate:	16,5 l/min (4,36 gal/m)	Intake air flow rate:	0,85 m3/m

Rating conditions according to ISO 3046 (100 kPa barometric pressure, 30 % relative humidity and 25 °C (77 ° F))

* Maximum output power: maximum power supplied by the genset at full load

** Prime Power: rated power according to ISO 3046 and ISO 8528-1. 10 % overload capacity one hour in twelve hours.

1 kW \cong 1,36 CV 1 kW \cong 1,36 HP (metric) 1 kW \cong 1,36 CH

Fuel system details

Consumption 25%:	1,3 L/H (0,34 Gal/H)	Fuel type:	Diesel
Consumption 50%:	1,8 L/H (0,48 Gal/H)	Fuel standards:	Fueloil diesel ASTM
Consumption 75%:	2,3 L/H (0,61 Gal/H)	Injection pump type:	In line
Consumption 100%:	3 L/H (0,79 Gal/H)	Governor type:	Mechanical

Electrical system

Battery voltage:	12 V	Stop solenoid type:	ETR
Starter motor:	1,7 kW	Alternator:	65 A
Earth isolated:	Included		

Installation details

Exhaust hose inner diameter:	50 mm (1,97 in)	Maximum fuel lift height:	0,3 m (0,98 ft)
Sea water hose inner diameter:	20 mm (0,79 in)	Maximum raw water lift height:	1,3 m (51,18 in)
Fuel feeding hose inner diameter:	G3/8	Maximum sea water temperature:	32 °C (89,6 °F)
Fuel return hose inner diameter:	-	Maximum installation angle***:	15 °
Minimum battery capacity:	12 V 65 Ah		

Alternator details

Brand:	Sincro	Cos φ:	1
Model:	SK 160 CA 1	Tropicalized:	Yes
Regulator type:	BL4	Excitation system:	BRUSHLESS
Number of poles:	4	Voltage regulation accuracy**:	1%
Isolation type*:	H	Standards:	EN 60034-1, IEC 60034-1, ISO 8528-3
IP protection*:	23	Alternator type:	Synchronous

Standard equipment

Earth isolated	Spray stop kit
Double wall injection pipes and fuel leak alarm	Sensors certified by the rating company
Dual fuel filter kit	Reinforced bed and silentblocks
Control panel for CO-40 engine	6 m wiring extension
Documentation: manual, test, declaration of conformity	Packaging
Belt protection	Oil extraction pump

Optional accessories

Siphon break kit mandatory if generator is below waterline	Water Filters
Engine electrical system at 24 V	Sea water cock
Service/Cruise Kits: fuel and oil filters, raw water pump, impeller, alternator belt,...	Welcome Kit
Dry Exhaust system	Fuel filter/water separator
Exhaust System	Gas/Water Separator
Keel Cooling conversion for dry and wet exhaust	Raw water hose
Electronic regulator	Paralel system
Electronic actuator	TAC certificate by serial number for generator set
Exhaust Hose	

* Other protections available

** With load from 0 to 100%, speed variation from -2% up to +5%, power factor 0,8 linear and balanced load.

*** In all directions

For other requirements please contact the Sales Dept.



COMAP PANEL CO 40



General Description

- Control, monitoring and protection for marine engines (signal alternator not included)
- For Emergency, Auxiliary, Harbor and Propulsion engines
- Redundant module ID-RPU with hardwired safety functions activated in backup mode
- Switching between primary and secondary battery (with ID-RPU module)
- Connection to engine via primary J1939 and backup J1587 buses
- Event driven History record
- 14 binary inputs, 14 binary outputs, 8 analog inputs
- Slave panels for remote control
- Type approval from major certification societies
- Configuration protected by password
- Running hour indication
- Multilanguage

ID – RPU Redundant Protection Unit

- 1 Emergency stop input
- 5 Shutdown inputs
- 1 RPM input
- Common warning and common shutdown output terminals
- Stop solenoid, fuel solenoid outputs
- Redundant power supply
- I/O broken wire detection

Technical data

- Power supply: Nominal power supply 24 VDC
- Power supply range 6 - 36 VDC
- Current consumption (depends on supply voltage)
0,34 A at 8 VDC 0,12 A at 24 VDC 0,09 A at 36 VDC
- Battery voltage measurement tolerance 2% at 24 V
- RTC battery life-cycle 10 year
- Operating temperature -10 to +70 °C
- Storage temperature -30 to +80 °C
- Humidity 95% Without condensation
- Flash memory data retention time 10 years

Standard Conformity

- Low Voltage Directive
EN 61010-1:95 +A1:97
- Electromagnetic Compatibility
EN 61000-6-2, October 2001
EN 61000-6-4, October 2001
IEC 60533, Ed. 2; 1999-11

Physical

- 180 x 120 mm front panel mounted case
- Weight 800g
- Graphic black-lit LCD display 128x64 pixel resolution with icons and bar graphs
- LED status indicators / Lamp test
- Protection front panel IP65

Display information

- Oil Pressure (bar)
- Oil Temperature (°C)
- Coolant Temperature (°C)
- Coolant Pressure (bar)
- Battery Voltage (V)
- RPM
- History log

Alarm Management

- High coolant temperature
- High oil temperature
- Fuel leakages
- Low oil pressure
- Low coolant pressure
- Overspeed
- Emergency stop
- Low battery voltage
- Maintenance request
- Sensor Fails (FLS)

Dimensions

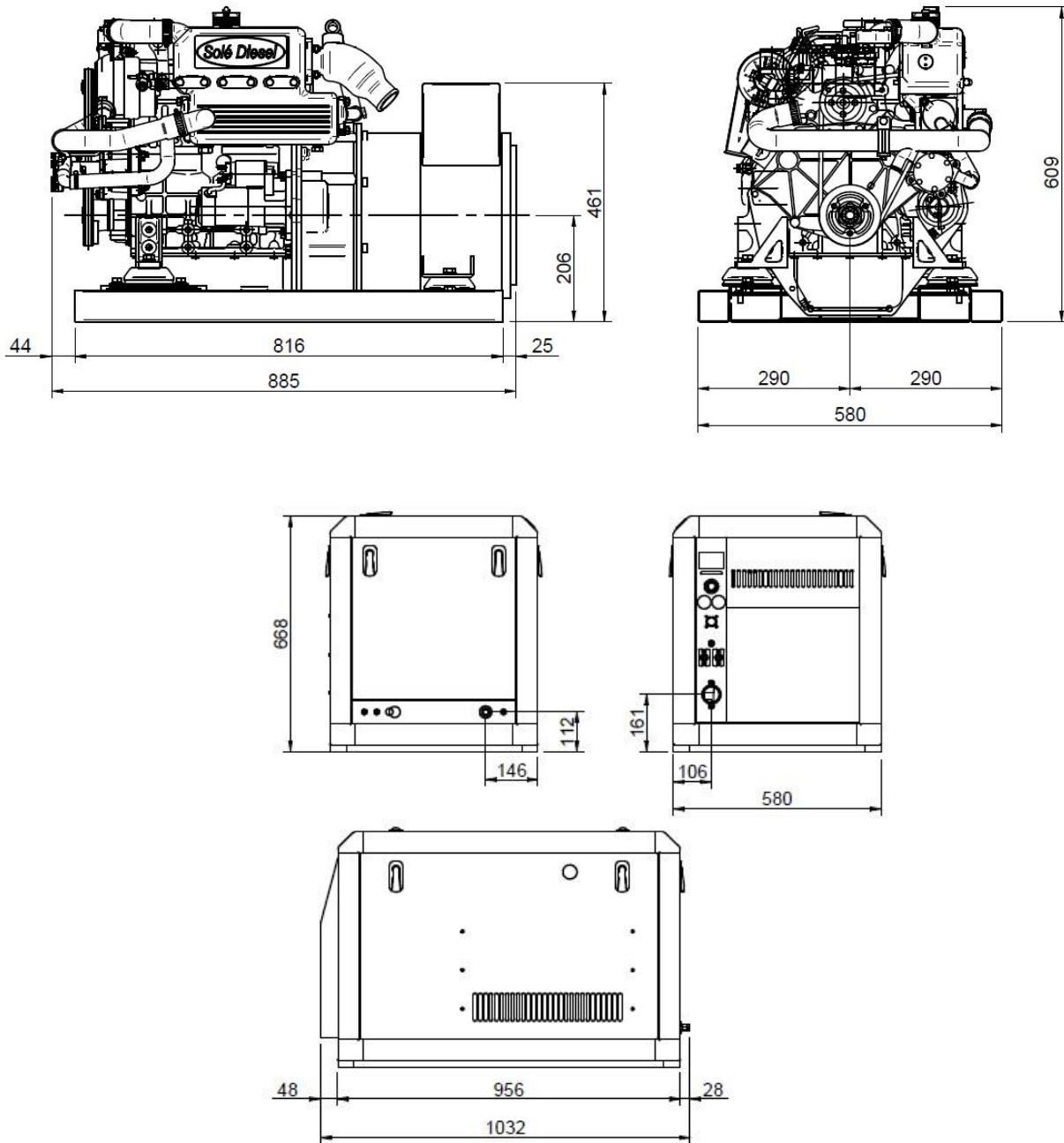

Authorized dealer

www.solediesel.com

info@solediesel.com

Detailed drawings, brochures and manuals are available on the web [solediesel.com](http://www.solediesel.com). All rights reserved. Technical specifications, data and presentation are subjected to variations, changes and updates without prior notice. Non-contractual information.