

**14 GS/GSC 230 V TAC**

Single-Phase

**General data**

<b>Maximum power*:</b>	13,2 kW (13,2 kVA)	<b>Voltage:</b>	230 V
<b>Prime Power**:</b>	12 kW	<b>Amperage:</b>	57,39 A
<b>Frequency:</b>	50 Hz	<b>Phases:</b>	1

**Dimensions and weights**

<b>Total length without canopy:</b>	1036 mm	<b>Total length with canopy:</b>	1181 mm
<b>Total width without canopy:</b>	580 mm	<b>Total width with canopy:</b>	580 mm
<b>Total height without canopy:</b>	612 mm	<b>Total height with canopy:</b>	668 mm
<b>Dry weight without canopy:</b>	294 Kg	<b>Dry weight with canopy:</b>	344 Kg

**Engine**

<b>Base engine manufacturer:</b>	Mitsubishi	<b>Diameter:</b>	78 mm (3,07 in)
<b>Model Solé Diesel:</b>	MINI-44	<b>Stroke:</b>	92 mm (3,62 in)
<b>Type:</b>	4 No. of Strokes	<b>Compression ratio:</b>	22:1
<b>Engine RPM:</b>	1500	<b>Injection system:</b>	Mechanical and indirect
<b>Number of cylinders:</b>	4	<b>Intake system:</b>	Naturally aspirated
<b>Total displacement:</b>	1758 cc	<b>SAE Flywheel housing:</b>	SAE 5
<b>Oil:</b>	SAE 15W40	<b>Coolant capacity:</b>	8 L (2,11 gal)
<b>Oil capacity:</b>	6 L (1,59 gal)	<b>Flywheel:</b>	SAE 7 1/2
<b>Power:</b>	14,6 kW (19,86 CV)	<b>Coolant flow rate:</b>	100 l/min (26,42 gal/m)
<b>Salt water flow rate:</b>	33 l/min (8,72 gal/m)	<b>Intake air flow rate:</b>	2,2 m3/m

Rating conditions according to ISO 3046 (100 kPa barometric pressure, 30 % relative humidity and 25 °C (77 ° F))

\* Maximum output power: maximum power supplied by the genset at full load

\*\* Prime Power: rated power according to ISO 3046 and ISO 8528-1. 10 % overload capacity one hour in twelve hours.

1 kW  $\cong$  1,36 CV 1 kW  $\cong$  1,36 HP (metric) 1 kW  $\cong$  1,36 CH

## Fuel system details

<b>Consumption 25%:</b>	1,8 L/H (0,48 Gal/H)	<b>Fuel type:</b>	Diesel
<b>Consumption 50%:</b>	2,6 L/H (0,69 Gal/H)	<b>Fuel standards:</b>	Fueloil diesel ASTM
<b>Consumption 75%:</b>	3,4 L/H (0,9 Gal/H)	<b>Injection pump type:</b>	In line
<b>Consumption 100%:</b>	4,1 L/H (1,08 Gal/H)	<b>Governor type:</b>	Mechanical

## Electrical system

<b>Battery voltage:</b>	12 V	<b>Stop solenoid type:</b>	ETR
<b>Starter motor:</b>	1,7 kW	<b>Alternator:</b>	120 A
<b>Earth isolated:</b>	Included		

## Installation details

<b>Exhaust hose inner diameter:</b>	50 mm (1,97 in)	<b>Maximum fuel lift height:</b>	0,3 m (0,98 ft)
<b>Sea water hose inner diameter:</b>	20 mm (0,79 in)	<b>Maximum raw water lift height:</b>	3 m (118,11 in)
<b>Fuel feeding hose inner diameter:</b>	G3/8	<b>Maximum sea water temperature:</b>	32 °C (89,6 °F)
<b>Fuel return hose inner diameter:</b>	1/4 BSPT	<b>Maximum installation angle***:</b>	15 °
<b>Minimum battery capacity:</b>	12 V 80 Ah		

## Alternator details

<b>Brand:</b>	Sincro	<b>Cos φ:</b>	1
<b>Model:</b>	SK 160 MA 1	<b>Tropicalized:</b>	Yes
<b>Regulator type:</b>	BL4	<b>Excitation system:</b>	BRUSHLESS
<b>Number of poles:</b>	4	<b>Voltage regulation accuracy**:</b>	1%
<b>Isolation type*:</b>	H	<b>Standards:</b>	EN 60034-1, IEC 60034-1, ISO 8528-3
<b>IP protection*:</b>	23	<b>Alternator type:</b>	Synchronous

## Standard equipment

Earth isolated	Spray stop kit
Double wall injection pipes and fuel leak alarm	Sensors certified by the rating company
Dual fuel filter kit	Reinforced bed and silentblocks
Control panel for CO-40 engine	6 m wiring extension
Documentation: manual, test, declaration of conformity	Packaging
Belt protection	Oil extraction pump

## Optional accessories

Siphon break kit mandatory if generator is below waterline	Water Filters
Engine electrical system at 24 V	Sea water cock
Service/Cruise Kits: fuel and oil filters, raw water pump, impeller, alternator belt,...	Welcome Kit
Dry Exhaust system	Fuel filter/water separator
Exhaust System	Gas/Water Separator
Keel Cooling conversion for dry and wet exhaust	Raw water hose
Electronic regulator	Paralel system
Electronic actuator	TAC certificate by serial number for generator set
Exhaust Hose	

\* Other protections available

\*\* With load from 0 to 100%, speed variation from -2% up to +5%, power factor 0,8 linear and balanced load.

\*\*\* In all directions

For other requirements please contact the Sales Dept.



# COMAP PANEL CO 40



## General Description

- Control, monitoring and protection for marine engines (signal alternator not included)
- For Emergency, Auxiliary, Harbor and Propulsion engines
- Redundant module ID-RPU with hardwired safety functions activated in backup mode
- Switching between primary and secondary battery (with ID-RPU module)
- Connection to engine via primary J1939 and backup J1587 buses
- Event driven History record
- 14 binary inputs, 14 binary outputs, 8 analog inputs
- Slave panels for remote control
- Type approval from major certification societies
- Configuration protected by password
- Running hour indication
- Multilanguage

## ID – RPU Redundant Protection Unit

- 1 Emergency stop input
- 5 Shutdown inputs
- 1 RPM input
- Common warning and common shutdown output terminals
- Stop solenoid, fuel solenoid outputs
- Redundant power supply
- I/O broken wire detection

## Technical data

- Power supply: Nominal power supply 24 VDC
- Power supply range 6 - 36 VDC
- Current consumption (depends on supply voltage)  
0,34 A at 8 VDC 0,12 A at 24 VDC 0,09 A at 36 VDC
- Battery voltage measurement tolerance 2% at 24 V
- RTC battery life-cycle 10 year
- Operating temperature -10 to +70 °C
- Storage temperature -30 to +80 °C
- Humidity 95% Without condensation
- Flash memory data retention time 10 years

## Standard Conformity

- Low Voltage Directive  
EN 61010-1:95 +A1:97
- Electromagnetic Compatibility  
EN 61000-6-2, October 2001  
EN 61000-6-4, October 2001  
IEC 60533, Ed. 2; 1999-11

## Physical

- 180 x 120 mm front panel mounted case
- Weight 800g
- Graphic black-lit LCD display 128x64 pixel resolution with icons and bar graphs
- LED status indicators / Lamp test
- Protection front panel IP65

## Display information

- Oil Pressure (bar)
- Oil Temperature (°C)
- Coolant Temperature (°C)
- Coolant Pressure (bar)
- Battery Voltage (V)
- RPM
- History log

## Alarm Management

- High coolant temperature
- High oil temperature
- Fuel leakages
- Low oil pressure
- Low coolant pressure
- Overspeed
- Emergency stop
- Low battery voltage
- Maintenance request
- Sensor Fails (FLS)

## Dimensions

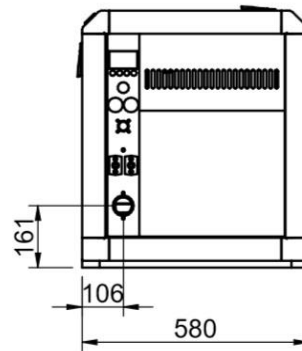
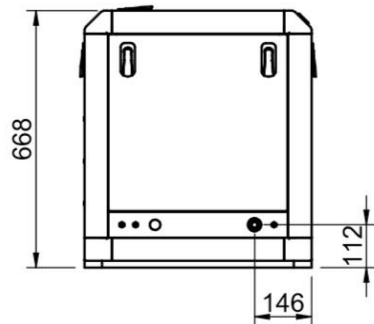
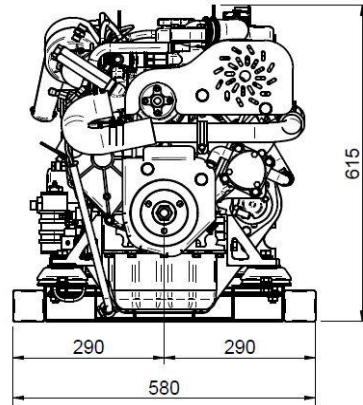
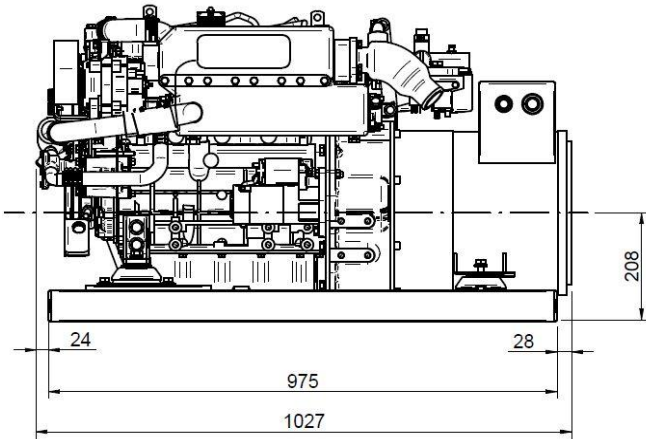

Authorized dealer

[www.solediesel.com](http://www.solediesel.com)

[info@solediesel.com](mailto:info@solediesel.com)

Detailed drawings, brochures and manuals are available on the web [solediesel.com](http://www.solediesel.com). All rights reserved. Technical specifications, data and presentation are subjected to variations, changes and updates without prior notice. Non-contractual information.