



## MARINE GENERATORS

# 40 GTA/GTAC 240 TAC

Three-Phase

### General data

<b>Maximum power*</b>	30.8 kW (38.5 kVA)	<b>Voltage</b>	240 V
<b>Prime Power**</b>	28 kW	<b>Amperage</b>	92.62 A
<b>Frequency</b>	60 Hz	<b>Phases</b>	3

### Dimensions and weights

<b>Total length without canopy</b>	1308 mm	<b>Total length with canopy</b>	1445 mm
<b>Total width without canopy</b>	630 mm	<b>Total width with canopy</b>	630 mm
<b>Total height without canopy</b>	733 mm	<b>Total height with canopy</b>	788 mm
<b>Dry weight without canopy</b>	494 Kg	<b>Dry weight with canopy</b>	545 Kg

### Engine

<b>Base engine manufacturer</b>	Mitsubishi	<b>Diameter</b>	94 mm (3.7 in)
<b>Model</b>	MINI-74	<b>Stroke</b>	120 mm (4.72 in)
<b>Type</b>	Diesel, 4 stroke	<b>Compression ratio</b>	22:1
<b>Engine RPM</b>	1800	<b>Injection system</b>	Mechanical and direct
<b>Number of cylinders</b>	4	<b>Intake system</b>	Naturally aspirated
<b>Total displacement</b>	3331 cc	<b>SAE Flywheel housing</b>	SAE 3
<b>Oil</b>	SAE 15W40	<b>Coolant capacity</b>	13 L (3.43 gal)
<b>Oil capacity</b>	10 L (2.64 gal)	<b>Flywheel</b>	SAE 11 1/2
<b>Power</b>	33.1 kW (45.02 CV)	<b>Coolant flow rate</b>	105 l/min (27.74 gal/m)
<b>Salt water flow rate</b>	37.5 l/min (9.91 gal/m)	<b>Intake air flow rate</b>	2.25 m3/m
<b>Exhaust type</b>	Wet exhaust elbow	<b>V-Belt Protection</b>	Included

Rating conditions according to ISO 3046 (100 kPa barometric pressure, 30 % relative humidity abd 25 °C (77 ° F))

\* Maximum output power: maximum power supplied by the genset at full load

\*\* Prime Power: rated power according to ISO 3046 and ISO 8528-1. 10 % overload capacity one hour in twelve hours.

Fuel system details

1 kW □ 1,36 CV 1 kW □ 1,36 HP (metric) 1 kW □ 1,36 CH

45611 - 11/24

## Fuel system details

<b>Consumption 25%</b>	3 l/h (0.79 gal)	<b>Fuel type</b>	Diesel
<b>Consumption 50%</b>	4.8 l/h (1.27 gal)	<b>Fuel standards</b>	Fueloil diesel ASTM
<b>Consumption 75%</b>	6.9 l/h (1.82 gal)	<b>Injection pump type</b>	In line
<b>Consumption 100%</b>	9.7 l/h (2.56 gal)	<b>Governor type</b>	Mechanical

## Electrical system

<b>Battery voltage</b>	24 V	<b>Stop solenoid type</b>	ETR
<b>Starter motor</b>	2.2 kW	<b>Alternator</b>	50 A
<b>Earth isolated</b>	Included	<b>IP 65 box kit</b>	Optional
<b>SCO 11 double panel</b>	Optional	<b>Current transformers</b>	Optional

## Installation details

<b>Exhaust hose inner diameter</b>	75 mm (2.95 in)	<b>Maximum fuel lift height</b>	0.6 m (1.97 ft)
<b>Sea water hose inner diameter</b>	32 mm (1.26 in)	<b>Maximum raw water lift height</b>	2.5 m (98.43 in)
<b>Fuel feeding hose inner diameter</b>	G1/8	<b>Maximum sea water temperature</b>	32 ° (89.6 °F)
<b>Fuel return hose inner diameter</b>	-	<b>Maximum installation angle***</b>	15 °
<b>Minimum battery capacity</b>	24 V 95 Ah		

## Alternator details

<b>Brand</b>	Sincro	<b>Cos Phi</b>	0,8
<b>Model</b>	SK 160 WB	<b>Tropicalized</b>	Yes
<b>Regulator type</b>	BL4	<b>Excitation system</b>	Brushless
<b>Number of poles</b>	4	<b>Voltage regulation accuracy**</b>	1
<b>Isolation type*</b>	H	<b>Alternator type</b>	Synchronous
<b>IP protection</b>	23	<b>Standards</b>	EN 60034-1, IEC 60034-1, ISO 8528-3

## Standard equipment

Earth isolated	Spray stop kit
Double wall injection pipes and fuel leak alarm	Sensors certified by the rating company
Dual fuel filter kit	Reinforced bed and silentblocks
CO-40 panel for engine/prime mover	6 m wiring extension
Documentation: manual, test, declaration of conformity	Packaging
V-Belt Protection	Oil extraction pump

## Optional accessories

Siphon break kit mandatory if generator is below waterline	Keel Cooling conversion for dry and wet exhaust
Engine electrical system at 24 V	Electronic regulator
Service/Cruise Kits: fuel and oil filters, raw water pump, impeller, alternator belt,...	Electronic actuator
Dry Exhaust system	Exhaust Hose
Exhaust System	

\* Other protections available

\*\* With load from 0 to 100%, speed variation from -2% up to +5%, power factor 0,8 linear and balanced load.

\*\*\* In all directions

For other requirements please contact the Sales Dept.

# CO 40 panel



## General Description

Control, monitoring and protection for marine engines (signal alternator not included)
For Emergency, Auxiliary, Harbor and Propulsion engines
Redundant module ID-RPU with hardwired safety functions activated in backup mode
Switching between primary and secondary battery (with ID-RPU module)
Connection to engine via primary J1939 and backup J1587 buses
Event driven History record
14 binary inputs, 14 binary outputs, 8 analog inputs
Slave panels for remote control
Type approval from major certification societies
Configuration protected by password
Running hour indication
Multilanguage
D+ pre-excitation Terminal

## Alarm Management

1 Emergency stop input
5 Shutdown inputs
1 RPM input
Common warning and common shutdown output terminals
Stop solenoid, fuel solenoid outputs
Redundant power supply
I/O broken wire detection

## Operating modes

Power supply: Nominal power supply 24 VDC	Flash memory data retention time 10 years
Power supply range 6 - 36 VDC	Standard Conformity
Current consumption (depends on supply voltage) 0,34 A at 8 VDC 0,12 A at 24 VDC 0,09 A at 36 VDC	Low Voltage Directive EN 61010-1:95 +A1:97
Battery voltage measurement tolerance 2% at 24 V	Electromagnetic Compatibility EN 61000-6-2, October 2001
RTC battery life-cycle 10 year	EN 61000-6-4, October 2001
Operating temperature -10 to +70 °C	IEC 60533, Ed. 2; 1999-11
Storage temperature -30 to +80 °C	
Humidity 95% Without condensation	

## Power Supply

180 x 120 mm front panel mounted case
Weight 800g
Graphic black-lit LCD display 128x64 pixel resolution with icons and bar graphs
LED status indicators / Lamp test
Protection front panel IP65

## Operating Conditions

Oil Pressure (bar)
Oil Temperature (°C)
Coolant Temperature (°C)
Coolant Pressure (bar)
Battery Voltage (V)
RPM
History log

## Display Information

High coolant temperature
High oil temperature
Fuel leakages
Low oil pressure
Low coolant pressure
Overspeed
Emergency stop
Low battery voltage
Maintenance request
Sensor Fails (FLS)

## Dimensions

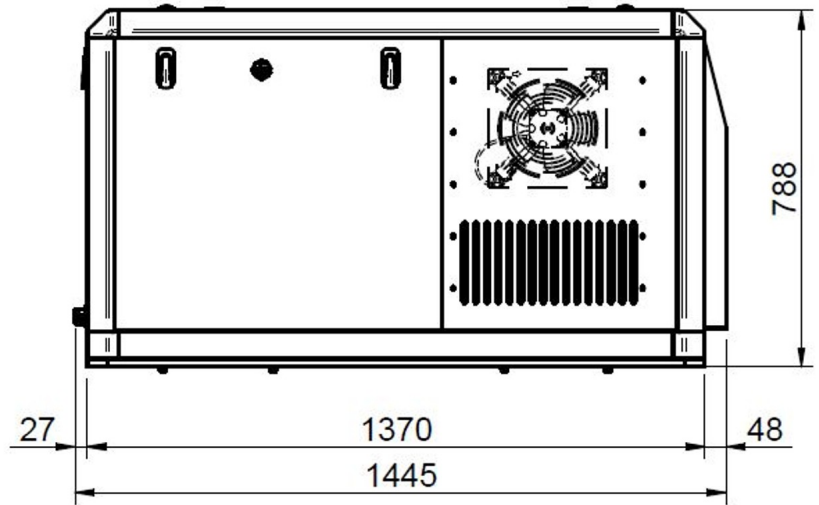
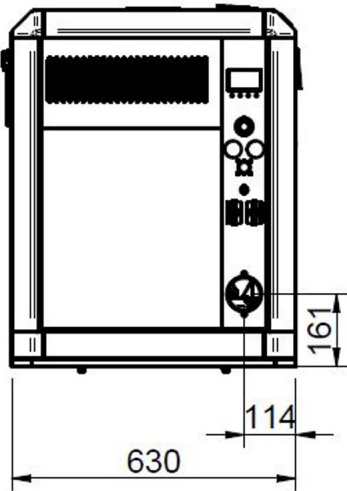
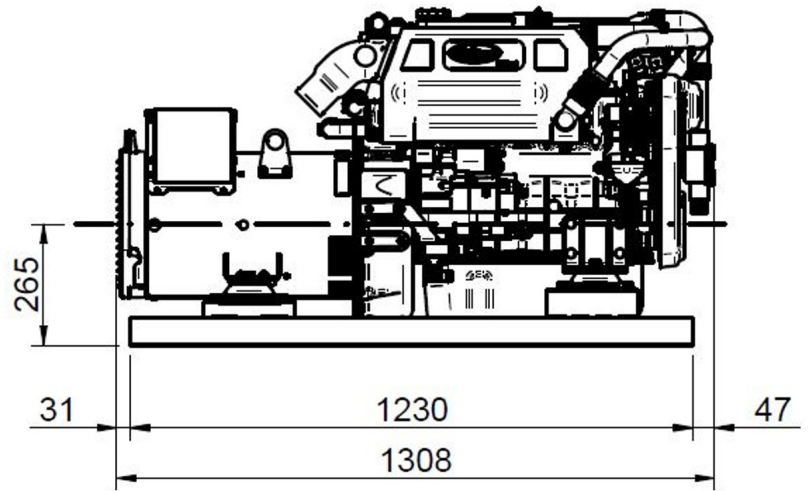
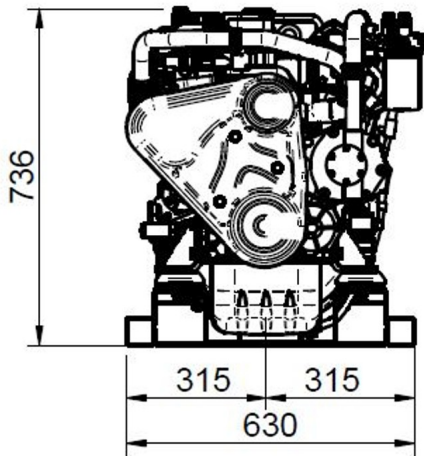

Detailed drawings, brochures and manuals are available on the web [soleadvance.com](http://soleadvance.com). All rights reserved.  
Technical specifications, data and presentation are subjected to variations, changes and updates without prior notice.  
Non-contractual information.



Authorized dealer