

# 25 GSA/ GSAC PARALLEL

Single-Phase

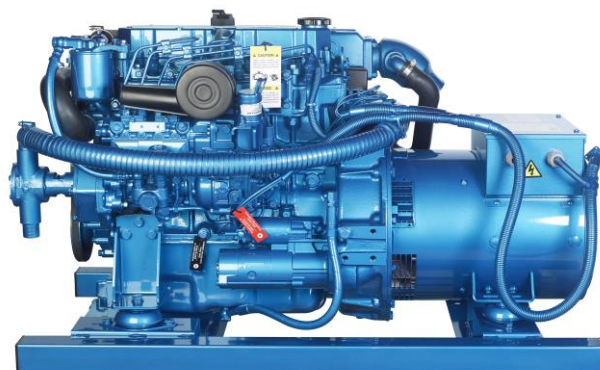

## General data

<b>Maximum power*:</b>	25,1 kW (25,1 kVA)	<b>Voltage:</b>	240 V
<b>Prime Power**:</b>	22,8 kW	<b>Amperage:</b>	104,6 A
<b>Frequency:</b>	60 Hz	<b>Phases:</b>	1

## Dimensions and weights

<b>Total length without canopy:</b>	1140 mm	<b>Total length with canopy:</b>	1310 mm
<b>Total width without canopy:</b>	610 mm	<b>Total width with canopy:</b>	610 mm
<b>Total height without canopy:</b>	662 mm	<b>Total height with canopy:</b>	698 mm
<b>Dry weight without canopy:</b>	402 Kg	<b>Dry weight with canopy:</b>	426 Kg

## Engine

<b>Base engine manufacturer:</b>	Mitsubishi	<b>Diameter:</b>	88 mm (3,46 in)
<b>Model Solé Diesel:</b>	MINI-63	<b>Stroke:</b>	103 mm (4,06 in)
<b>Type:</b>	4 No. of Strokes	<b>Compression ratio:</b>	22:1
<b>Engine RPM:</b>	1800	<b>Injection system:</b>	Mechanical and indirect
<b>Number of cylinders:</b>	4	<b>Intake system:</b>	Naturally aspirated
<b>Total displacement:</b>	2505 cc	<b>SAE Flywheel housing:</b>	SAE 4
<b>Oil:</b>	SAE 15W40	<b>Coolant capacity:</b>	9,5 L (2,51 gal)
<b>Oil capacity:</b>	6,5 L (1,72 gal)	<b>Flywheel:</b>	SAE 7 1/2
<b>Power:</b>	27,2 kW (36,99 CV)	<b>Coolant flow rate:</b>	65 l/min (17,17 gal/m)
<b>Salt water flow rate:</b>	45 l/min (11,89 gal/m)	<b>Intake air flow rate:</b>	2,1 m3/m

Rating conditions according to ISO 3046 (100 kPa barometric pressure, 30 % relative humidity and 25 °C (77 ° F))

\* Maximum output power: maximum power supplied by the genset at full load

\*\* Prime Power: rated power according to ISO 3046 and ISO 8528-1. 10 % overload capacity one hour in twelve hours.

1 kW  $\cong$  1,36 CV 1 kW  $\cong$  1,36 HP (metric) 1 kW  $\cong$  1,36 CH

## Fuel system details

<b>Consumption 25%:</b>	2,9 L/H (0,77 Gal/H)	<b>Fuel type:</b>	Diesel
<b>Consumption 50%:</b>	4,2 L/H (1,11 Gal/H)	<b>Fuel standards:</b>	Fueloil diesel ASTM
<b>Consumption 75%:</b>	5,5 L/H (1,45 Gal/H)	<b>Injection pump type:</b>	In line
<b>Consumption 100%:</b>	7,6 L/H (2,01 Gal/H)	<b>Governor type:</b>	Mechanical

## Electrical system

<b>Battery voltage:</b>	12 V	<b>Stop solenoid type:</b>	ETR
<b>Starter motor:</b>	2 kW	<b>Alternator:</b>	50 A

## Installation details

<b>Exhaust hose inner diameter:</b>	60 mm (2,36 in)	<b>Maximum fuel lift height:</b>	0,6 m (1,97 ft)
<b>Sea water hose inner diameter:</b>	32 mm (1,26 in)	<b>Maximum raw water lift height:</b>	3,5 m (137,8 in)
<b>Fuel feeding hose inner diameter:</b>	8 mm (0,31 in)	<b>Maximum sea water temperature:</b>	32 °C (89,6 °F)
<b>Fuel return hose inner diameter:</b>	-	<b>Maximum installation angle***:</b>	15 °
<b>Minimum battery capacity:</b>	12 V 95 Ah		

## Alternator details

<b>Brand:</b>	Sincro	<b>Cos φ:</b>	1
<b>Model:</b>	SK160LA1	<b>Tropicalized:</b>	Yes
<b>Regulator type:</b>	BL4	<b>Excitation system:</b>	BRUSHLESS
<b>Number of poles:</b>	4	<b>Voltage regulation accuracy**:</b>	1%
<b>Isolation type*:</b>	H	<b>Standards:</b>	EN 60034-1, IEC 60034-1, ISO 8528-3
<b>IP protection*:</b>	23	<b>Alternator type:</b>	Synchronous

## Standard equipment

Earth-isolated	6 m extension prepared for parallel
Silentblocks	Parallel genset manual
Oil extraction pump	Packaging
Electric actuator	

## Optional accessories

Siphon break kit mandatory if generator is below waterline	Keel Cooling conversion for dry and wet exhaust
Engine electrical system at 24 V	Double walled pipes and alarm kit
Service/Cruise Kits: fuel and oil filters, raw water pump, impeller, alternator belt,..	Low coolant level shut down switch
Dry Exhaust system	Fuel filter/water separator
Wet Exhaust System	Gas/Water Separator
Water Filters	Fuel Hose
Sea water cock	Exhaust Hose
Welcome Kit	Raw water hose

\* Other protections available

\*\* With load from 0 to 100%, speed variation from -2% up to +5%, power factor 0,8 linear and balanced load.

\*\*\* In all directions

For other requirements please contact the Sales Dept.



# Optional: Parallel Kit Electrical Cabinet



## General Description

- Control and Power box for parallel operation
- COMAP Intelligen200 Panel (See Panel Features)
- Current Transformers (See Alternator Measurements)
- Power Isolating Switch
- Automatic Synchronism
- Marine Generator Set Protections (See Alarm Management)
- Power and Control Electrical Protection
- Communication Control Cable Extensions (See Extensions)
- Power inputs and outputs
- Automatic or manual control switch
- Audible and visual alarm
- Can BUS communication with the control unit and the parallel box
- Emergency Stop button
- IP 65 Protection

## Alarm Management

### Shut-down (SD)

- High engine coolant temperature
- Low oil pressure
- Over speed
- Overload
- Short circuit
- Battery charge failure
- High/low voltage
- High/Low Frequency
- Emergency stop button
- Remote alarms

### Warnings (WRN)

- High engine coolant temperature
- Low oil pressure
- High/low battery voltage
- Maintenance warning

## Optional Equipment

### Intelligen200 Remote Double Panel

- It allows the same operation and functionality as main Intelligen200
- They are connected with an RS485 port
- Remote panel extension (12/24/36 m)

### Binary and Communication Input/Output Extension Module

## Alternator Measurements

### Current transformers

#### Allows the following readings:

- Current (A), Active Power (kW), Apparent Power (kVA) and PF

### Earth isolated transformers

## Extension

### Control wiring. Box-Group (6/12/24 m)

#### Mitsubishi / Deutz

- 60974209 / 60994210P - 6 m
- 60974212 / 60994212P - 12 m
- 60974213 / 60994213P - 24 m

### Wiring for communication between boxes (3/6/12 m)

- 60994503 - 3 m
- 60994522 - 6 m
- 60994521 - 12 m

### Remote panel extension (12/24/36 m)

- 60972104 - 12 m
- 60972105 - 24 m
- 60972110 - 36 m

## Intelligen200 Panel Features

- Group and load Synchronization
- Marine generator set measures
- L1-L3 Voltage (V), frequency (Hz), Oil pressure (bar)
- Coolant temperature (°C), battery voltage (V), RPM
- Power\* (kW), Apparent Power\* (kVA), Current\* (A), PF\*
- Remote panel
- 2 x 10 A Binary outputs
- History log
- Running hour indicator
- Multilanguage
- Configuration protected by password
- Integrated PLC
- Communication and Extension Module Plug-in
- 4G/LTE communication standard
- GPS

## Dimensions

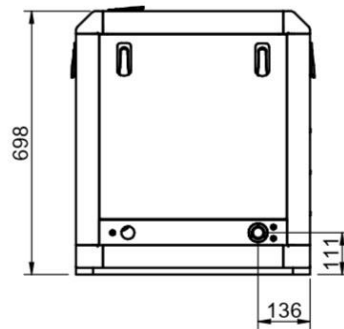
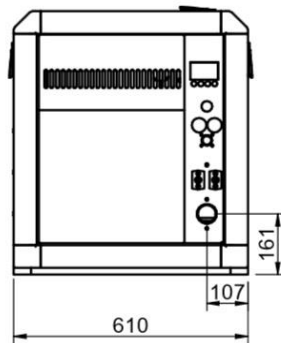
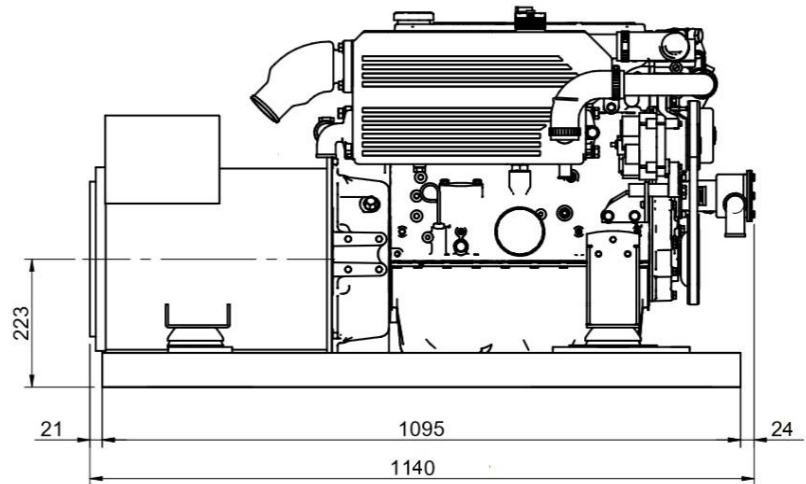
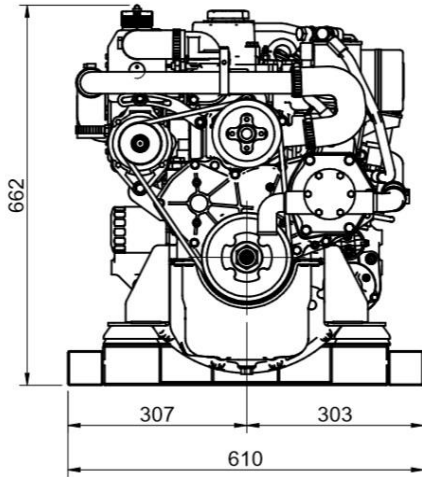

Authorized dealer

[www.solediesel.com](http://www.solediesel.com)  
[info@solediesel.com](mailto:info@solediesel.com)

Detailed drawings, brochures and manuals are available on the web [solediesel.com](http://www.solediesel.com). All rights reserved. Technical specifications, data and presentation are subjected to variations, changes and updates without prior notice. Non-contractual information.