



MARINE GENERATORS

45 GT/GTC TAC 230 V

Three-Phase

General data

| | | | |
|-----------------------|------------------|-----------------|----------|
| Maximum power* | 35.2 kW (44 kVA) | Voltage | 230 V |
| Prime Power** | 32 kW | Amperage | 110.45 A |
| Frequency | 50 Hz | Phases | 3 |

Dimensions and weights

| | | | |
|------------------------------------|---------|---------------------------------|---------|
| Total length without canopy | 1423 mm | Total length with canopy | 1605 mm |
| Total width without canopy | 740 mm | Total width with canopy | 740 mm |
| Total height without canopy | 788 mm | Total height with canopy | 841 mm |
| Dry weight without canopy | 605 Kg | Dry weight with canopy | 650 Kg |

Engine

| | | | |
|---------------------------------|------------------------|-----------------------------|-------------------------|
| Base engine manufacturer | Mitsubishi | Diameter | 94 mm (3.7 in) |
| Model | SM-56 | Stroke | 120 mm (4.72 in) |
| Type | Diesel, 4 stroke | Compression ratio | 17:1 |
| Engine RPM | 1500 | Injection system | Mechanical and direct |
| Number of cylinders | 4 | Intake system | Turbocharged |
| Total displacement | 3331 cc | SAE Flywheel housing | SAE 3 |
| Oil | SAE 15W40 | Coolant capacity | 13 L (3.43 gal) |
| Oil capacity | 10 L (2.64 gal) | Flywheel | SAE 11 1/2 |
| Power | 37.8 kW (51.41 CV) | Coolant flow rate | 105 l/min (27.74 gal/m) |
| Salt water flow rate | 38 l/min (10.04 gal/m) | Intake air flow rate | 2.9 m3/m |
| Exhaust type | Wet exhaust elbow | V-Belt Protection | Included |

Rating conditions according to ISO 3046 (100 kPa barometric pressure, 30 % relative humidity abd 25 °C (77 ° F))

* Maximum output power: maximum power supplied by the genset at full load

** Prime Power: rated power according to ISO 3046 and ISO 8528-1. 10 % overload capacity one hour in twelve hours.

Fuel system details

1 kW □ 1,36 CV 1 kW □ 1,36 HP (metric) 1 kW □ 1,36 CH

45611 - 11/24

Fuel system details

| | | | |
|-------------------------|--------------------|----------------------------|---------------------|
| Consumption 25% | 3.1 l/h (0.82 gal) | Fuel type | Diesel |
| Consumption 50% | 5.1 l/h (1.35 gal) | Fuel standards | Fueloil diesel ASTM |
| Consumption 75% | 7.3 l/h (1.93 gal) | Injection pump type | In line |
| Consumption 100% | 9.6 l/h (2.54 gal) | Governor type | Mechanical |

Electrical system

| | | | |
|----------------------------|----------|-----------------------------|----------|
| Battery voltage | 12 V | Stop solenoid type | ETR |
| Starter motor | 2.2 kW | Alternator | 50 A |
| Earth isolated | Included | IP 65 box kit | Optional |
| SCO 11 double panel | Included | Current transformers | Optional |

Installation details

| | | | |
|---|-----------------|--------------------------------------|------------------|
| Exhaust hose inner diameter | 75 mm (2.95 in) | Maximum fuel lift height | 0.3 m (0.98 ft) |
| Sea water hose inner diameter | 32 mm (1.26 in) | Maximum raw water lift height | 2.5 m (98.43 in) |
| Fuel feeding hose inner diameter | G3/8 | Maximum sea water temperature | 32 ° (89.6 °F) |
| Fuel return hose inner diameter | G1/8 | Maximum installation angle*** | 15 ° |
| Minimum battery capacity | 12 V 95 Ah | | |

Alternator details

| | | | |
|------------------------|--------------|--------------------------------------|------------------------|
| Brand | Meccalte | Cos Phi | 0,8 |
| Model | ECP32 1M 4 C | Tropicalized | Yes |
| Regulator type | DSR | Excitation system | Brushless |
| Number of poles | 4 | Voltage regulation accuracy** | 0,01 |
| Isolation type* | H | Alternator type | Synchronous |
| IP protection | 23 | Standards | EN60034-1, IEC 60034-1 |

Standard equipment

| | |
|--|---|
| Earth isolated | Spray stop kit |
| Double wall injection pipes and fuel leak alarm | Sensors certified by the rating company |
| Dual fuel filter kit | Reinforced bed and silentblocks |
| CO-40 panel for engine/prime mover | 6 m wiring extension |
| Documentation: manual, test, declaration of conformity | Packaging |
| V-Belt Protection | Oil extraction pump |

Optional accessories

| | |
|--|---|
| Siphon break kit mandatory if generator is below waterline | Keel Cooling conversion for dry and wet exhaust |
| Engine electrical system at 24 V | Electronic regulator |
| Service/Cruise Kits: fuel and oil filters, raw water pump, impeller, alternator belt,... | Electronic actuator |
| Dry Exhaust system | Exhaust Hose |
| Exhaust System | |

* Other protections available

** With load from 0 to 100%, speed variation from -2% up to +5%, power factor 0,8 linear and balanced load.

*** In all directions

For other requirements please contact the Sales Dept.

CO 40 panel



General Description

Control, monitoring and protection for marine engines

(signal alternator not included)

For Emergency, Auxiliary, Harbor and Propulsion engines

Redundant module ID-RPU with hardwired safety

functions activated in backup mode

Switching between primary and secondary battery

(with ID-RPU module)

Connection to engine via primary J1939 and backup J1587 buses

Event driven History record

14 binary inputs, 14 binary outputs, 8 analog inputs

Slave panels for remote control

Type approval from major certification societies

Configuration protected by password

Running hour indication

Multilanguage

D+ pre-excitation Terminal

Alarm Management

1 Emergency stop input

5 Shutdown inputs

1 RPM input

Common warning and common shutdown output terminals

Stop solenoid, fuel solenoid outputs

Redundant power supply

I/O broken wire detection

Operating modes

Power supply: Nominal power supply 24 VDC

Power supply range 6 - 36 VDC

Current consumption (depends on supply voltage)

0,34 A at 8 VDC 0,12 A at 24 VDC 0,09 A at 36 VDC

Battery voltage measurement tolerance 2% at 24 V

RTC battery life-cycle 10 year

Operating temperature -10 to +70 °C

Storage temperature -30 to +80 °C

Humidity 95% Without condensation

Power Supply

180 x 120 mm front panel mounted case

Weight 800g

Graphic black-lit LCD display 128x64 pixel resolution with icons

and bar graphs

LED status indicators / Lamp test

Protection front panel IP65

Operating Conditions

Oil Pressure (bar)

Oil Temperature (°C)

Coolant Temperature (°C)

Coolant Pressure (bar)

Battery Voltage (V)

RPM

History log

Display Information

High coolant temperature

High oil temperature

Fuel leakages

Low oil pressure

Low coolant pressure

Overspeed

Emergency stop

Low battery voltage

Maintenance request

Sensor Fails (FLS)

Flash memory data retention time 10 years

Standard Conformity

Low Voltage Directive

EN 61010-1:95 +A1:97

Electromagnetic Compatibility

EN 61000-6-2, October 2001

EN 61000-6-4, October 2001

IEC 60533, Ed. 2; 1999-11

Dimensions

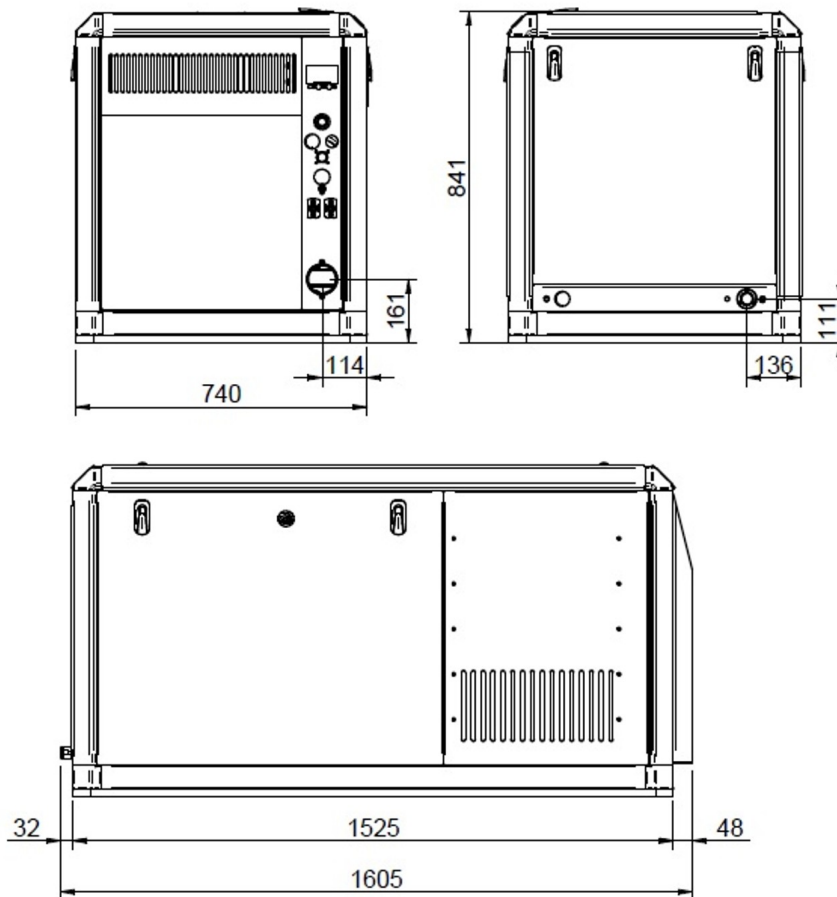
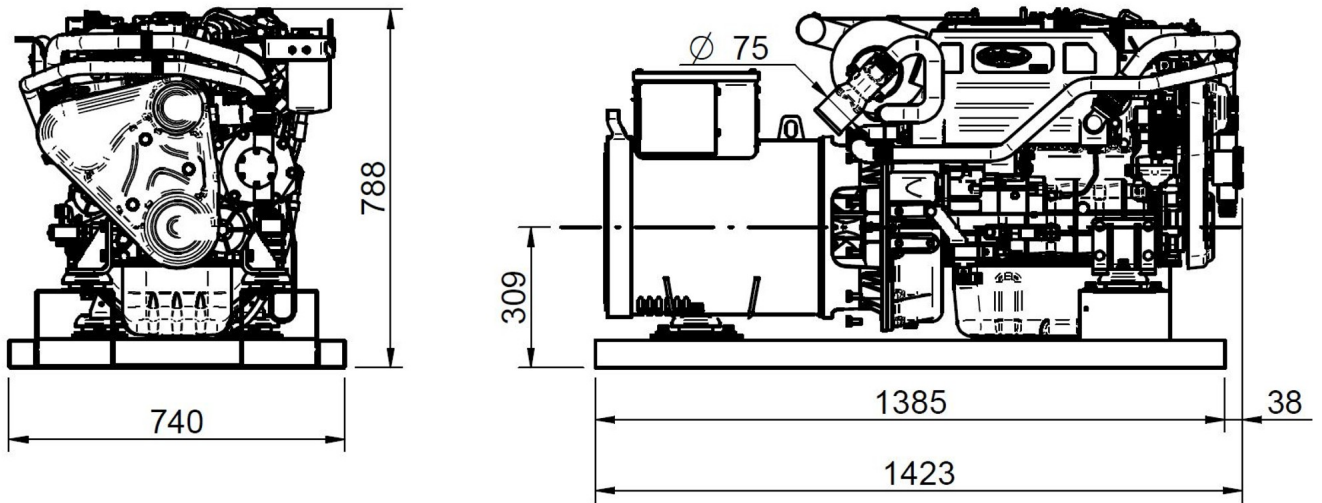

Authorized dealer



Detailed drawings, brochures and manuals are available on the web soleadvantage.com. All rights reserved. Technical specifications, data and presentation are subjected to variations, changes and updates without prior notice. Non-contractual information.

