

# 68 GT/GTC PARALLEL

**Three-Phase**

## General data

<b>Maximum power*:</b>	54,7 kW (68,36 kVA)	<b>Voltage:</b>	400/230 V
<b>Prime Power**:</b>	49,7 kW	<b>Amperage:</b>	98,7 A
<b>Frequency:</b>	50 Hz	<b>Phases:</b>	3

## Dimensions and weights

<b>Total length without canopy:</b>	1723 mm	<b>Total length with canopy:</b>	1903 mm
<b>Total width without canopy:</b>	700 mm	<b>Total width with canopy:</b>	840 mm
<b>Total height without canopy:</b>	800 mm	<b>Total height with canopy:</b>	848 mm
<b>Dry weight without canopy:</b>	759 Kg	<b>Dry weight with canopy:</b>	869 Kg

## Engine

<b>Base engine manufacturer:</b>	Mitsubishi	<b>Diameter:</b>	94 mm (3,7 in)
<b>Model Solé Diesel:</b>	SM-81	<b>Stroke:</b>	120 mm (4,72 in)
<b>Type:</b>	4 No. of Strokes	<b>Compression ratio:</b>	17:1
<b>Engine RPM:</b>	1500	<b>Injection system:</b>	Mechanical and indirect
<b>Number of cylinders:</b>	6	<b>Intake system:</b>	Turbocharged
<b>Total displacement:</b>	4996 cc	<b>SAE Flywheel housing:</b>	SAE 3
<b>Oil type:</b>	SAE 15W40	<b>Coolant capacity:</b>	21 L (5,55 gal)
<b>Oil capacity:</b>	12 L (3,17 gal)	<b>Flywheel:</b>	SAE 11 1/2
<b>Power:</b>	59,6 kW (81,06 CV)	<b>Coolant flow rate:</b>	70 l/min (18,49 gal/m)
<b>Salt water flow rate:</b>	38 l/min (10,04 gal/m)	<b>Intake air flow rate:</b>	4,2 m3/m

Rating conditions according to ISO 3046 (100 kPa barometric pressure, 30 % relative humidity and 25 °C (77 ° F))

\* Maximum output power: maximum power supplied by the genset at full load

\*\* Prime Power: rated power according to ISO 3046 and ISO 8528-1. 10 % overload capacity one hour in twelve hours.

1 kW  $\cong$  1,36 CV 1 kW  $\cong$  1,36 HP (metric) 1 kW  $\cong$  1,36 CH

## Fuel system details

<b>Consumption 25%:</b>	4,8 L/H (1,27 Gal/H)	<b>Fuel type:</b>	Diesel
<b>Consumption 50%:</b>	7,8 L/H (2,06 Gal/H)	<b>Fuel standards:</b>	Fueloil diesel ASTM
<b>Consumption 75%:</b>	11 L/H (2,91 Gal/H)	<b>Injection pump type:</b>	In line
<b>Consumption 100%:</b>	14,5 L/H (3,83 Gal/H)	<b>Governor type:</b>	Mechanical

## Electrical system

<b>Battery voltage:</b>	12 V	<b>Stop solenoid type:</b>	ETR
<b>Starter motor:</b>	3 kW	<b>Alternator:</b>	50 A

## Installation details

<b>Exhaust hose inner diameter:</b>	90 mm (3,54 in)	<b>Maximum fuel lift height:</b>	0,6 m (1,97 ft)
<b>Sea water hose inner diameter:</b>	32 mm (1,26 in)	<b>Maximum raw water lift height:</b>	2,5 m (98,43 in)
<b>Fuel feeding hose inner diameter:</b>	10 mm (0,39 in)	<b>Maximum sea water temperature:</b>	32 °C (89,6 °F)
<b>Fuel return hose inner diameter:</b>	10 mm (0,39 in)	<b>Maximum installation angle***:</b>	15 °
<b>Minimum battery capacity:</b>	12 V 120 Ah		

## Alternator details

<b>Brand:</b>	Meccalte	<b>Cos φ:</b>	0,8
<b>Model:</b>	ECP32-3L/4B	<b>Tropicalized:</b>	Yes
<b>Regulator type:</b>	DSR	<b>Excitation system:</b>	Brushless
<b>Number of poles:</b>	4	<b>Voltage regulation accuracy**:</b>	1%
<b>Isolation type*:</b>	H	<b>Standards:</b>	EN60034-1, IEC 60034-1
<b>IP protection*:</b>	23	<b>Alternator type:</b>	Synchronous

## Standard equipment

<b>Earth isolated</b>	<b>Electronic actuator</b>
<b>Silentblocks</b>	<b>Extension prepared for 6 m parallel</b>
<b>Oil extraction pump</b>	<b>Parallel group manual</b>

## Optional accessories

Siphon break kit mandatory if generator is below waterline	Keel Cooling conversion for dry and wet exhaust
Engine electrical system at 24 V	Double walled pipes and alarm kit
Service/Cruise Kits: fuel and oil filters, raw water pump, impeller, alternator belt,...	Low coolant level shut down switch
Dry Exhaust system	Fuel filter/water separator
Wet Exhaust System	Gas/Water Separator
Water Filters	Fuel Hose
Sea water cock	Exhaust Hose
Welcome Kit	Raw water hose

\* Other protections available

\*\* With load from 0 to 100%, speed variation from -2% up to +5%, power factor 0,8 linear and balanced load.

\*\*\* In all directions

For other requirements please contact the Sales Dept.



# Optional: Parallel Kit Electrical Cabinet



## General Description

- Control and Power box for parallel operation
- COMAP Intelligen200 Panel (See Panel Features)
- Current Transformers (See Alternator Measurements)
- Power Isolating Switch
- Automatic Synchronism
- Marine Generator Set Protections (See Alarm Management)
- Power and Control Electrical Protection
- Communication Control Cable Extensions (See Extensions)
- Power inputs and outputs
- Automatic or manual control switch
- Audible and visual alarm
- Can BUS communication with the control unit and the parallel box
- Emergency Stop button
- IP 65 Protection

## Alarm Management

### Shut-down (SD)

- High engine coolant temperature
- Low oil pressure
- Over speed
- Overload
- Short circuit
- Battery charge failure
- High/low voltage
- High/Low Frequency
- Emergency stop button
- Remote alarms

### Warnings (WRN)

- High engine coolant temperature
- Low oil pressure
- High/low battery voltage
- Maintenance warning

## Optional Equipment

### Intelligen200 Remote Double Panel

- It allows the same operation and functionality as main Intelligen200
- They are connected with an RS485 port
- Remote panel extension (12/24/36 m)

### Binary and Communication Input/Output Extension Module

## Alternator Measurements

### Current transformers

#### Allows the following readings:

- Current (A), Active Power (kW), Apparent Power (kVA) and PF

### Earth isolated transformers

## Extension

### Control wiring, Box-Group (6/12/24 m)

#### Mitsubishi / Deutz

- 60974209 / 60994210P - 6 m
- 60974212 / 60994212P - 12 m
- 60974213 / 60994213P - 24 m

### Wiring for communication between boxes (3/6/12 m)

- 60994503 - 3 m
- 60994522 - 6 m
- 60994521 - 12 m

### Remote panel extension (12/24/36 m)

- 60972104 - 12 m
- 60972105 - 24 m
- 60972110 - 36 m

## Intelligen200 Panel Features

- Group and load Synchronization
- Marine generator set measures
- L1-L3 Voltage (V), frequency (Hz), Oil pressure (bar)
- Coolant temperature (°C), battery voltage (V), RPM
- Power\* (kW), Apparent Power\* (kVA), Current\* (A), PF\*
- Remote panel
- 2 x 10 A Binary outputs
- History log
- Running hour indicator
- Multilanguage
- Configuration protected by password
- Integrated PLC
- Communication and Extension Module Plug-in
- 4G/LTE communication standard
- GPS

## Dimensions

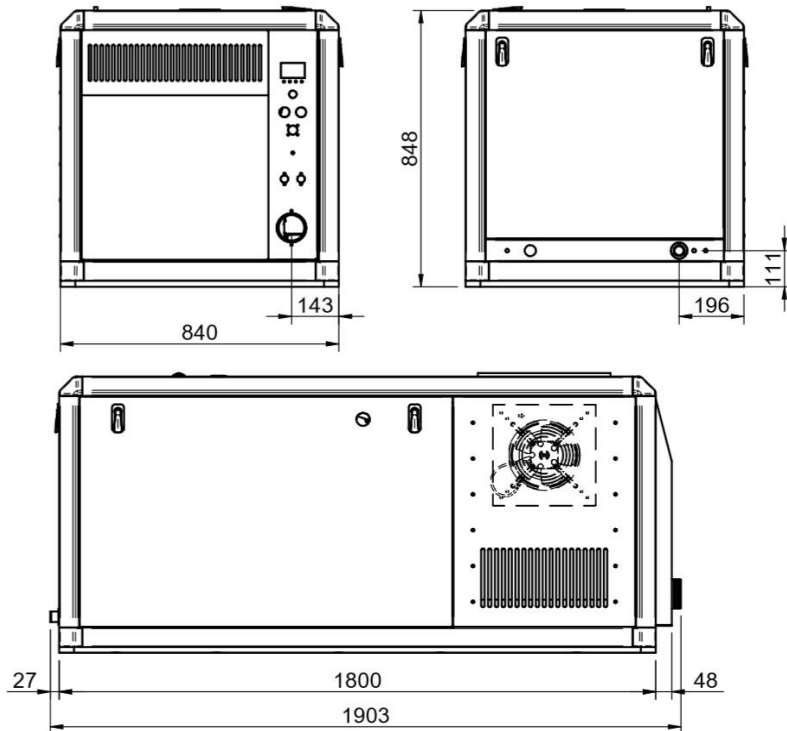
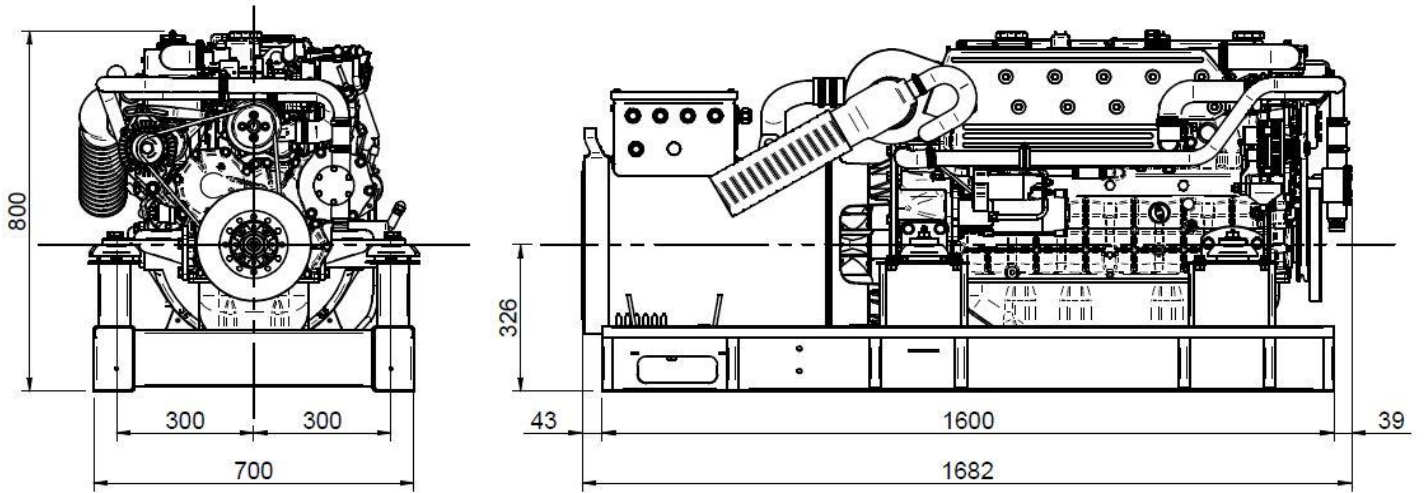

Authorized dealer

[www.solediesel.com](http://www.solediesel.com)  
[info@solediesel.com](mailto:info@solediesel.com)

Detailed drawings, brochures and manuals are available on the web [solediesel.com](http://www.solediesel.com). All rights reserved. Technical specifications, data and presentation are subjected to variations, changes and updates without prior notice. Non-contractual information.