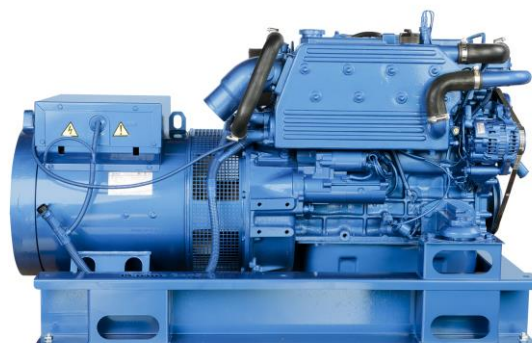

35 GT/GTC PARALLEL

Three-Phase

General data

Maximum power*:	28 kW (35 kVA)	Voltage:	400/230 V
Prime Power**:	25,5 kW	Amperage:	50,5 A
Frequency:	50 Hz	Phases:	3

Dimensions and weights

Total length without canopy:	1308 mm	Total length with canopy:	1445 mm
Total width without canopy:	630 mm	Total width with canopy:	630 mm
Total height without canopy:	732 mm	Total height with canopy:	788 mm
Dry weight without canopy:	494 Kg	Dry weight with canopy:	545 Kg

Engine

Base engine manufacturer:	Mitsubishi	Diameter:	94 mm (3,7 in)
Model Solé Diesel:	MINI-74	Stroke:	120 mm (4,72 in)
Type:	4 No. of Strokes	Compression ratio:	22:1
Engine RPM:	1500	Injection system:	Mechanical and indirect
Number of cylinders:	4	Intake system:	Naturally aspirated
Total displacement:	3331 cc	SAE Flywheel housing:	SAE 3
Oil type:	SAE 15W40	Coolant capacity:	13 L (3,43 gal)
Oil capacity:	10 L (2,64 gal)	Flywheel:	SAE 11 1/2
Power:	30,8 kW (41,89 CV)	Coolant flow rate:	105 l/min (27,74 gal/m)
Salt water flow rate:	37,5 l/min (9,91 gal/m)	Intake air flow rate:	2,25 m ³ /m

Rating conditions according to ISO 3046 (100 kPa barometric pressure, 30 % relative humidity and 25 °C (77 ° F))

* Maximum output power: maximum power supplied by the genset at full load

** Prime Power: rated power according to ISO 3046 and ISO 8528-1. 10 % overload capacity one hour in twelve hours.

1 kW \cong 1,36 CV 1 kW \cong 1,36 HP (metric) 1 kW \cong 1,36 CH

Fuel system details

Consumption 25%:	2,4 L/H (0,63 Gal/H)	Fuel type:	Diesel
Consumption 50%:	4,1 L/H (1,08 Gal/H)	Fuel standards:	Fueloil diesel ASTM
Consumption 75%:	6 L/H (1,59 Gal/H)	Injection pump type:	In line
Consumption 100%:	8,3 L/H (2,19 Gal/H)	Governor type:	Mechanical

Electrical system

Battery voltage:	12 V	Stop solenoid type:	ETR
Starter motor:	2,2 kW	Alternator:	50 A

Installation details

Exhaust hose inner diameter:	75 mm (2,95 in)	Maximum fuel lift height:	0,6 m (1,97 ft)
Sea water hose inner diameter:	32 mm (1,26 in)	Maximum raw water lift height:	2,5 m (98,43 in)
Fuel feeding hose inner diameter:	8 mm (0,31 in)	Maximum sea water temperature:	32 °C (89,6 °F)
Fuel return hose inner diameter:	#jVALORI	Maximum installation angle***:	15 °
Minimum battery capacity:	12 V 95 Ah		

Alternator details

Brand:	SINCRO	Cos φ:	0,8
Model:	SK160WA	Tropicalized:	Yes
Regulator type:	BL4	Excitation system:	BRUSHLESS
Number of poles:	4	Voltage regulation accuracy**:	1%
Isolation type*:	H	Standards:	EN 60034-1, IEC 60034-1, ISO 8528-3
IP protection*:	23	Alternator type:	Synchronous

Standard equipment

Earth isolated	Electronic actuator
Silentblocks	Extension prepared for 6 m parallel
Oil extraction pump	Parallel group manual

Optional accessories

Siphon break kit mandatory if generator is below waterline	Keel Cooling conversion for dry and wet exhaust
Engine electrical system at 24 V	Double walled pipes and alarm kit
Service/Cruise Kits: fuel and oil filters, raw water pump, impeller, alternator belt,...	Low coolant level shut down switch
Dry Exhaust system	Fuel filter/water separator
Wet Exhaust System	Gas/Water Separator
Water Filters	Fuel Hose
Sea water cock	Exhaust Hose
Welcome Kit	Raw water hose

* Other protections available

** With load from 0 to 100%, speed variation from -2% up to +5%, power factor 0,8 linear and balanced load.

*** In all directions

For other requirements please contact the Sales Dept.



Optional: Parallel Kit Electrical Cabinet



General Description

- Control and Power box for parallel operation
- COMAP Intelligen200 Panel (See Panel Features)
- Current Transformers (See Alternator Measurements)
- Power Isolating Switch
- Automatic Synchronism
- Marine Generator Set Protections (See Alarm Management)
- Power and Control Electrical Protection
- Communication Control Cable Extensions (See Extensions)
- Power inputs and outputs
- Automatic or manual control switch
- Audible and visual alarm
- Can BUS communication with the control unit and the parallel box
- Emergency Stop button
- IP 65 Protection

Alarm Management

Shut-down (SD)

- High engine coolant temperature
- Low oil pressure
- Over speed
- Overload
- Short circuit
- Battery charge failure
- High/low voltage
- High/Low Frequency
- Emergency stop button
- Remote alarms

Warnings (WRN)

- High engine coolant temperature
- Low oil pressure
- High/low battery voltage
- Maintenance warning

Optional Equipment

Intelligen200 Remote Double Panel

- It allows the same operation and functionality as main Intelligen200
- They are connected with an RS485 port
- Remote panel extension (12/24/36 m)

Binary and Communication Input/Output Extension Module

Alternator Measurements

Current transformers

Allows the following readings:

- Current (A), Active Power (kW), Apparent Power (kVA) and PF

Earth isolated transformers

Extension

Control wiring, Box-Group (6/12/24 m)

Mitsubishi / Deutz

- 60974209 / 60994210P - 6 m
- 60974212 / 60994212P - 12 m
- 60974213 / 60994213P - 24 m

Wiring for communication between boxes (3/6/12 m)

- 60994503 - 3 m
- 60994522 - 6 m
- 60994521 - 12 m

Remote panel extension (12/24/36 m)

- 60972104 - 12 m
- 60972105 - 24 m
- 60972110 - 36 m

Intelligen200 Panel Features

- Group and load Synchronization
- Marine generator set measures
- L1-L3 Voltage (V), frequency (Hz), Oil pressure (bar)
- Coolant temperature (°C), battery voltage (V), RPM
- Power* (kW), Apparent Power* (kVA), Current* (A), PF*
- Remote panel
- 2 x 10 A Binary outputs
- History log
- Running hour indicator
- Multilanguage
- Configuration protected by password
- Integrated PLC
- Communication and Extension Module Plug-in
- 4G/LTE communication standard
- GPS

Dimensions

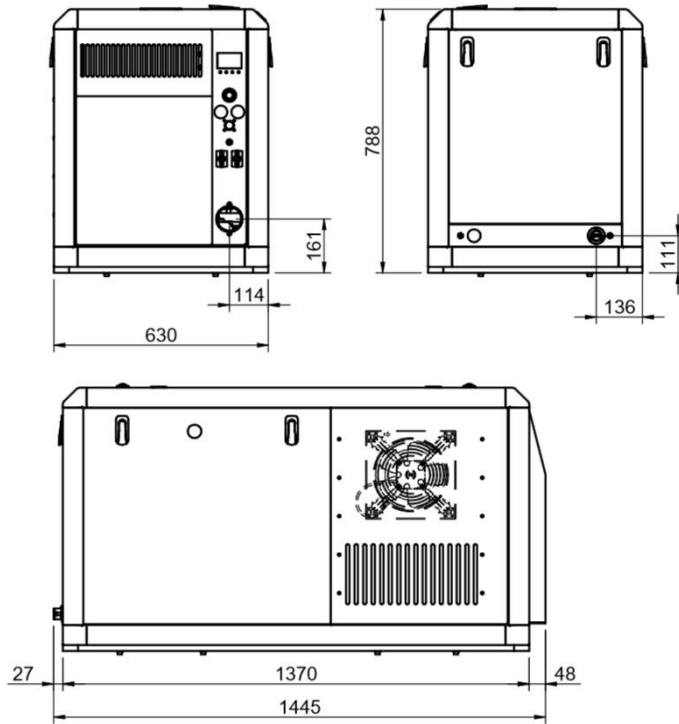
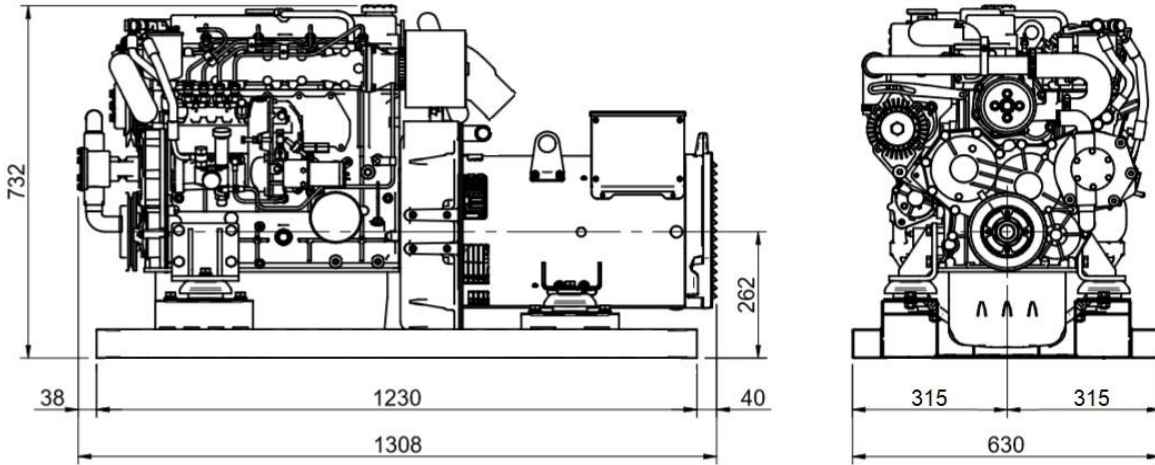

Authorized dealer

www.solediesel.com
info@solediesel.com

Detailed drawings, brochures and manuals are available on the web solediesel.com. All rights reserved. Technical specifications, data and presentation are subjected to variations, changes and updates without prior notice. Non-contractual information.